

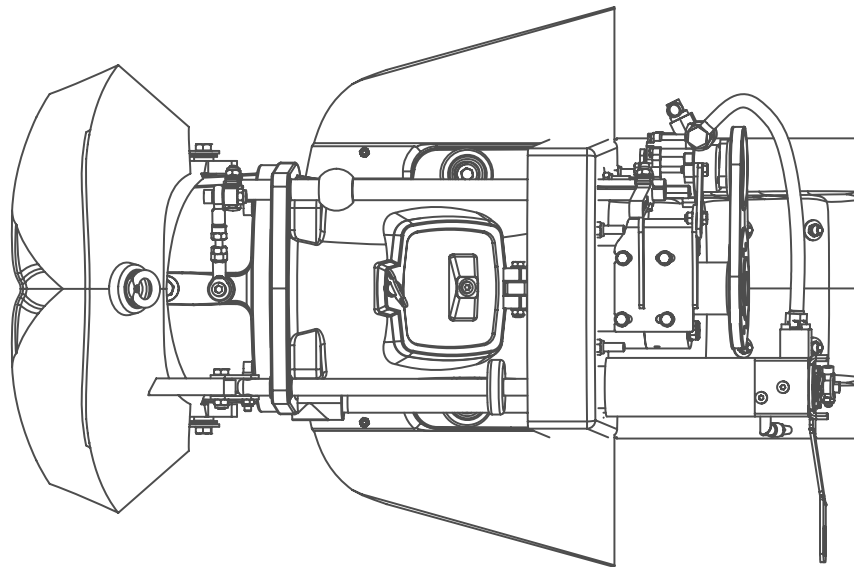

OPERATION AND MAINTENANCE MANUAL

AJ 160 | AJ 180 | AJ 185 | AJ 230



ALAMARIN-JET

We congratulate You on purchasing a new **alamarin-jet** water jet propulsion unit and hope that you can enjoy it.

Alamarin-Jet Oy has developed and manufactured water jet propulsion units since 1976. The propulsion units are used e.g. in pleasure and work boats, as well as in fast rescue boats with a number of different engines. Thousands of users around the world rely on the **alamarin-jet** water jet propulsion unit.

The aim of this instruction is to give important information on the operation, use and maintenance of the unit. We recommend reading this manual carefully before the implementation of the unit and before You set out to test Your new jet boat for the first time. This is how You get the most pleasure and benefit out of it.

With best regards,

The logo for Alamarin-Jet, featuring the brand name in a bold, italicized, sans-serif font. The word 'ALAMARIN' is in black, and 'JET' is in blue with a white outline. A stylized blue and white graphic element resembling a jet or a wave is positioned between 'ALAMARIN' and 'JET'.

Alamarin-Jet Oy
Tuomisentie 16
62300 Härmä
Finland

tel. +358-10-7745 260

www.alamarinjet.com

alamarin-jet water jet propulsion unit

OPERATION AND MAINTENANCE MANUAL

Alamarin-Jet Oy has published this manual in order to guide the owners and users of boats equipped with *alamarin-jet* water jet propulsion unit.

Alamarin-Jet Oy has published other manuals separately for technical designers, mechanics and repair men.

From here on in this manual the *alamarin-jet* water jet propulsion unit will be referred to as "jet". This term refers exclusively to a propulsion unit manufactured by Alamarin-Jet Oy.

The instruction covers the following jet propulsion models:

AJ 160 AJ 180 AJ 185 AJ 230

If the given information is type specific, this will be expressed in the text.

In this manual, clarifying figures will be used.

The symbols used in the manual:



ARROW DESCRIBING MOTION



INDICATOR ARROW



PART MARKING



HINT - the text includes useful additional information or a hint which facilitates the work performance or procedure



NOTE - the text includes a warning of a slight danger or a possibility of minor damage to equipment



GUARANTEE MATTER - the text includes a guarantee clause



WARNING - the text includes a warning of a danger that can lead to personal injury, breaking down of equipment or serious malfunction of equipment



SERIOUS DANGER - the text includes a warning of danger to life

After Sales Questionnaire.....	6
Declaration of Incorporation for Partially Completed Machinery	8
1. The Jet Propulsion Unit	9
2. Operation.....	10
2.1. Using for the First Time	10
2.2. Steering and Controlling.....	11
... 2.2.1. Steering.....	12
... 2.2.2. Controlling.....	12
2.3. Operating in Shallow Water.....	14
2.4. Operating in Reedy Water	15
2.5. Dry running.....	16
2.6. Cavitation and Ventilation.....	16
... 2.6.1. Cavitation	16
... 2.6.2. Ventilation	17
3. Functions	18
3.1. Transmission	18
3.2. Bearing	19
3.3. Control System.....	19
... 3.3.1. Electronic Reversing Deflector Control System	19
... 3.3.2. Hydraulic Reversing Deflector Control System.....	20
3.4. Raw Water Cooling	22
3.5. Corrosion Protection	22
... 3.5.1. Cathodic Protection.....	22
... 3.5.2. Painting.....	23
4. Maintenance.....	24
4.1. Tools	24
4.2. Periodical Maintenance	24
... 4.2.1. Washing the Jet	25
... 4.2.2 Lubricating the Bearings	25
... 4.2.3. Lubricating the Control System.....	26
... 4.2.4 Changing the Zinc Anodes.....	27
... 4.2.5. Adjusting the Impeller.....	27
... 4.2.6. Checking the Seals	27
... 4.2.7. Maintenance of the Hydraulic System	27
4.3. The Impeller	29
... 4.3.1. Removing the Impeller	31
... 4.3.2. Fitting the Impeller	33

APPENDIXES

Appendix 1. Maintenance Log.....	35
Appendix 2. SE-01.....	36
Appendix 3. SE-02.....	37
Appendix 4. Recommended Greases and Oils and Tightening Torques of the Screws	38
Appendix 5. Exploded Views	39
Appendix 6. Warranty & Ownership	40

AFTER SALES QUESTIONNAIRE

In order to improve our products and operations, we at Alamarin-Jet Oy are collecting feedback from the end users of water jet propulsion units. This form is intended to make it as simple as possible for you to give us that feedback. You can fill out the form in the User's Manual and send it to us via mail or fax, or scan and send it via e-mail.

Only answer questions to which you know the answer.

Customer's/end user's contact information:

(Boat owner)

Contact information of person answering the questionnaire:

Delivery information of project/device:

(For instance the serial number of the propulsion unit or other relevant document)

Test information for ALAMARIN-JET:

(Use table on the next page)

Customer service received from retailer/importer/manufacturer prior to delivery:

(Quotation, technical guidance, documentation, etc.)

Delivery of propulsion unit:

(Timeliness of delivery, contents of delivery, packaging, documentation)

After sales services:

(Include prior experiences of retailer's/manufacturer's services)

Spare parts services:

Other comments:



Return address: ALAMARIN-JET OY
 Tuomisentie 16
 FI-62300 HARMA
 FINLAND
 EUROPE

E-mail: sales@alamarinjet.com

TEST REPORT

Date:

Test weight of boat	Number of persons	Wind speed m/s	Water temperature
Jet serial number	Engine and gear	GPS/clock	Signature
Engine speed	Speed in direction 1	Speed in direction 2	Average speed
2400			
2500			
2600			
2700			
2800			
2900			
3000			
3100			
3200			
3300			
3400			
3500			
3600			
3700			
3800			
3900			
4000			
4100			
4200			
max rpm			

Notes:

If possible, include pictures in your feedback.

DECLARATION OF INCORPORATION FOR PARTIALLY
COMPLETED MACHINERY

(Machinery Directive 2006/42/EC, Annex II, 1.B.)

Manufacturer: Alamarin-Jet Oy
Tuomisentie 16
FI-62300 Härmä, Finland

Compiler of the technical file: Hannu Rantala, Technical Manager
Alamarin-Jet Oy
Tuomisentie 16
FI-62300 Härmä, Finland

Description of the partially completed machinery: Water jet propulsion device

Operation of the partially completed machinery: The device is intended to be used as the propulsion device of a motor boat. A propulsion device transforms the torque of the motor into propulsive force.

Model and type of the partially completed machinery: _____

Serial number of the partially completed machinery: _____

Alamarin-Jet Oy guarantees that the abovementioned partially completed machinery meets the requirements of the Machinery Directive (2006/42/EC) and the validating national regulations.

In addition, the company guarantees that

- the specific technical documents related to the partially completed machinery have been created according to section B of Annex VII in the Machinery Directive (2006/42/EC), and
- the following harmonised standards are applied: SFS-EN-ISO 12100-1 and SFS-EN-ISO 14121-1.

Alamarin-Jet Oy also undertakes to deliver the documents related to the partially completed machinery to the relevant national authority in electronic format if so requested.

The partially completed machinery must not be introduced to use before the final equipment to which it is intended to be attached has been declared to conform to the requirements of this Directive.

Place: Kauhava, Finland

Date and Signature

1. The Jet Propulsion Unit

Alamarin-jet water jet propulsion unit is a single stage axial flow pump, which produces a high volume flow rate and thrust with high efficiency.

The operation of the unit is based on increasing the water flow rate in the nozzle. The change in the flow rate creates a reacting force in the direction of the flow, which thrusts the boat forward. By changing the direction of the jet, it is possible to steer the boat in the desired direction.

Main Parts (figure 1-1):

The intake duct (A), whose function is to lead the water from outside the boat to the intake side of the impeller with as little loss as possible and an even distribution of velocity.

The impeller (B), which is rotated by the driving motor through direct drive, increases the water's flow rate.

The nozzle converts the pressure energy produced by the impeller to motion energy.

The steering device (C) is used to change the direction of the jet flow coming out of the nozzle, which creates the force needed for turning.

The controlling device (D)
Lowering the reversing deflector causes the boat to reverse. The direction of the jet flow changes obliquely forward under the boat, which is when the thrust is directed forward and down. The reversing deflector is also used for stopping the boat. See section: Steering and Controlling, page 10

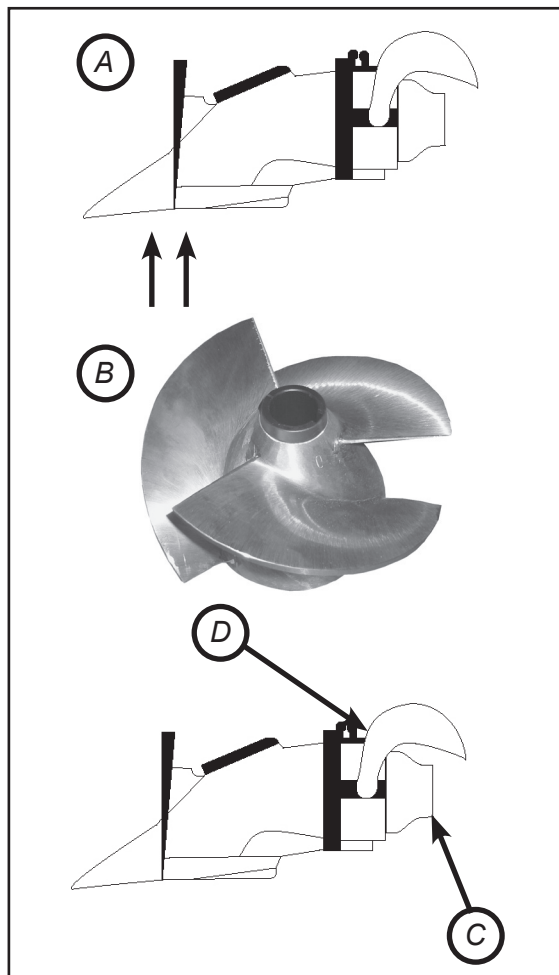

Figure 1-1

Every propulsion unit has its own serial number. The serial number has been marked on the type label and in addition it has been stamped both on the body of the propulsion unit and on the inspection hatch cover.



Figure 1-2

The places in which the serial number can be found have been designated in figures 1-2 and 1-3. The serial number has also been recorded on page 8 of the Instructions for Use and Maintenance.



Figure 1-3

2. Operation

2.1. Using for the First Time



Before you set the boat afloat for the first time, make sure that the jet has been installed according to the Installation Instruction.

This prevents the emergence of unexpected fault situations which can lead to damages.

Starting:

In starting an engine equipped with the jet, the following things should be observed:

- The reversing deflector control lever must be in centre position.
- The possible gear must be in "neutral" position.
- In a system without a gear the accelerator must be in "idle" position.

See the effect of the position of the reversing deflector control lever on the position of the reversing deflector on page 11.

When you start the engine for the first time:

- It may be possible that "clinking" is heard from the jet during the first minutes. This should usually disappear, however, when the impeller gap becomes fit.
- The reversing deflector's hydraulic control system needs more oil because the hoses and cooler are empty. The oil pump noise may be loud at first, but as the system fills up with oil the noise disappears. Observe the oil level in the beginning because leakages cause environmental pollution.
- Checking the oil level has been described in section 3.3.2. The oil type has been given in appendix 4.
- Ensure the functioning of the system carefully, at low speeds.
- Observe the engine manufacturer's instructions on running in. The jet does not require special running in.
- In a system that includes a gearbox, note the direction of the jet's rotation, which usually corresponds to the direction of the engine's rotation (counterclockwise from the rear of the boat). This is why the gear must usually be used in the "reverse" position when you want to engage the propulsion unit's drive.



WHEN THE ENGINE IS STARTED UP, THE INTERMEDIATE SHAFT AND THE MAIN SHAFT START TO ROTATE. AT THIS STAGE, IT IS NOT ALLOWED TO GO NEAR THE ROTATING PARTS!

THE INSPECTION HATCH MUST BE KEPT CLOSED WHILE THE ENGINE IS RUNNING!

2.2. Steering and Controlling



IN THIS SECTION, CONTROLLING THE jet boat IS DESCRIBED IN A WAY THAT IT IS DONE THROUGH A SYSTEM THAT HAS BEEN INSTALLED AS INTENDED BY THE MANUFACTURER.

Alamarin-Jet Oy IS NOT LIABLE FOR DAMAGES WHICH DERIVE FROM INCORRECT INSTALLATION OF THE SYSTEM.

Steering denotes exclusively moving the steering nozzle. Steering means changing the boat's bow angle.

Controlling denotes exclusively moving the reversing deflector. Controlling means changing the boat's driving direction (forward - astern).

2.2.1. Steering

The boat is steered by turning the steering wheel. The connection from the wheel to the steering lever can be either mechanical or hydraulic (figure 2.2.1-1). The lever moves the nozzle through the shaft and the joint.

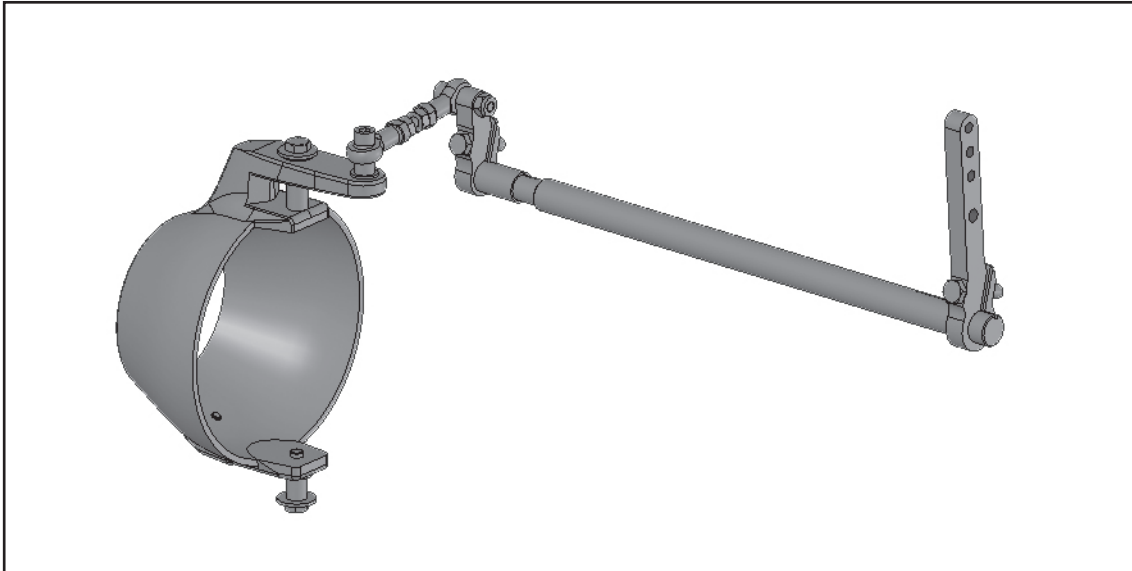

Figure 2.2.1-1

- Steering is possible when the power of the jet flow is sufficient. This is why the engine must run on sufficiently high revs when steering. 1200-1800 rpm is a suitable number of revolutions, depending on the engine.
- In sharp curves, turning the nozzle causes the boat to slow down. This is normal and increases safety.
- The turning of the nozzle from one extreme position to the other takes ~2 turns of the wheel.

2.2.2. Controlling

Driving direction is controlled with the reversing deflector. The reversing deflector is moved with the lever which is usually next to the throttle lever. With this lever, it is possible to control the hydraulic system mechanically or the mechanical system electrically.

In models AJ 160 and AJ 180/185 a fully mechanical system can be used, as long as it is sturdy enough.

The reversing deflector can be lowered in front of the jet flow, changing its direction forward and down. There are two different types of deflectors.

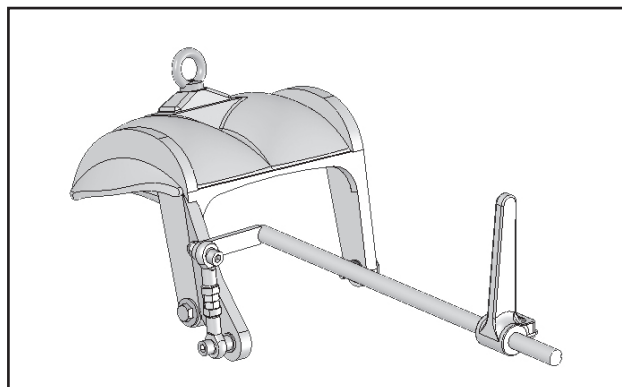

Figure 2.2.2-1

The round type reversing deflector (figure 2.2.2-1) fits in assemblies in which width is critical. By using the tube type reversing deflector (figure 2.2.2-2), a higher reversing power is attained, but the deflector is wider. The second tube-type reversing deflector model (figure 2.2.2-3) is primarily designed for twin installations, but it can also be used for single installations.

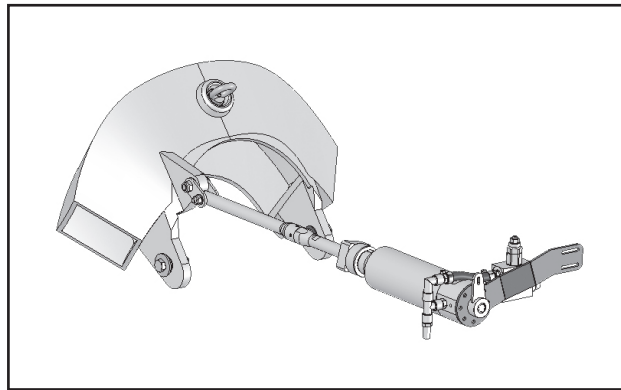

Figure 2.2.1-2

Figures 2.2.2-2 and 2.2.2-3 illustrate the hydraulic control system used in AJ 230.

For models AJ 160 and AJ 180/185, only the round type reversing deflector is available.

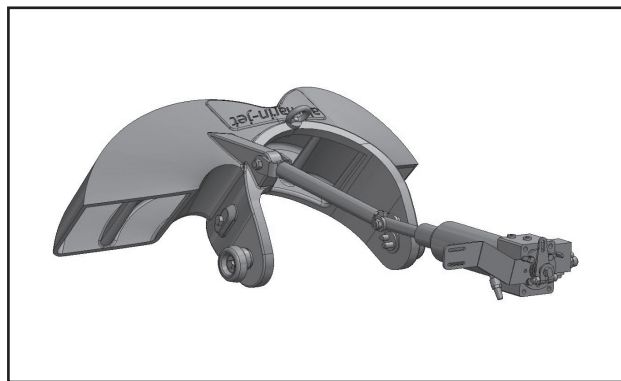

Figure 2.2.2-3

When the reversing deflector control lever is in forward position, the deflector is not blocking the jet flow and the boat moves forward (figure 2.2.2-4).

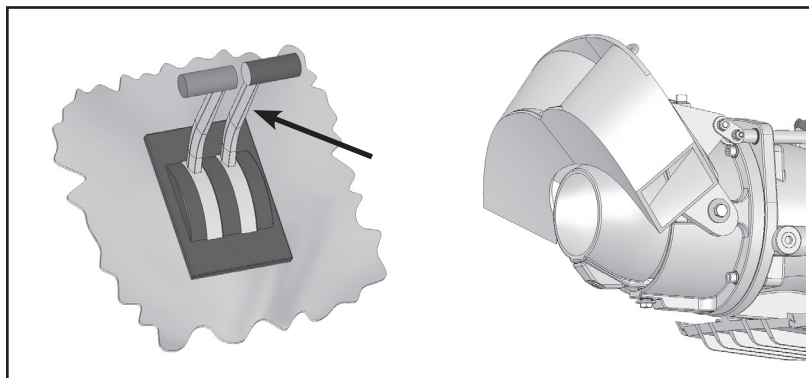

Figure 2.2.2-4

When the lever is in the rear position (figure 2.2.2-5), the deflector is in front of the jet flow and the boat moves astern.

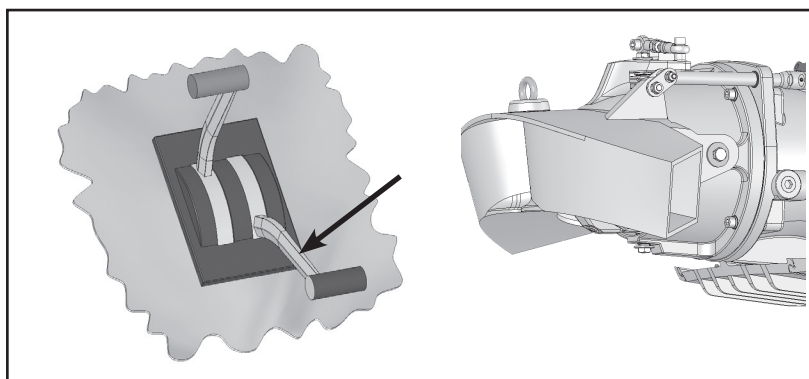

Figure 2.2.2-5

The centre position of the reversing deflector corresponds to gear's "idle" position; even though the drive is on, the boat stays still. *The centre position is not absolute, it depends on the power of the jet flow.* Finding the centre position is done by testing during the first driving hours.

When moving *at low speeds, the reversing deflector is used to control the boat's speed.* Because the engine is being run at 1200-1800 rpm to enhance steering, the boat may travel faster than desired. In this case the deflector is lowered in front of the jet flow to reduce the thrust directed towards the driving direction. Steerability remains good however.

At high speeds, the deflector is not used to reduce speed. Instead, speed is controlled with engine revolution.

It is possible to turn the boat in place when the deflector is in centre position. When the nozzle is turned to the desired direction, the boat rotates about its central axis.

When reversing, steering is inversed in comparison to driving forward. If you want to turn the boat to the left, the wheel must be turned to the right. A good mnemonic is that the boat's bow always turns in the same direction as the wheel.

When fast turns are needed, the engine revolutions are not reduced, but instead the turn is done through combined motion of the nozzle and the deflector.

2.3. Operating in Shallow Water

The jet boat can be used in very shallow water, but it must be taken into account that especially on high revolutions the suction power of the intake is high (cf. figure 2.3-1).

Loose objects may get sucked into the intake screen and small objects wash through the jet. Stones may cause damage. In sandy conditions wearing inevitably takes place. The maintenance procedures required by a worn impeller are described in the maintenance section of this manual. See Adjusting and Fitting the Impeller, page 24.

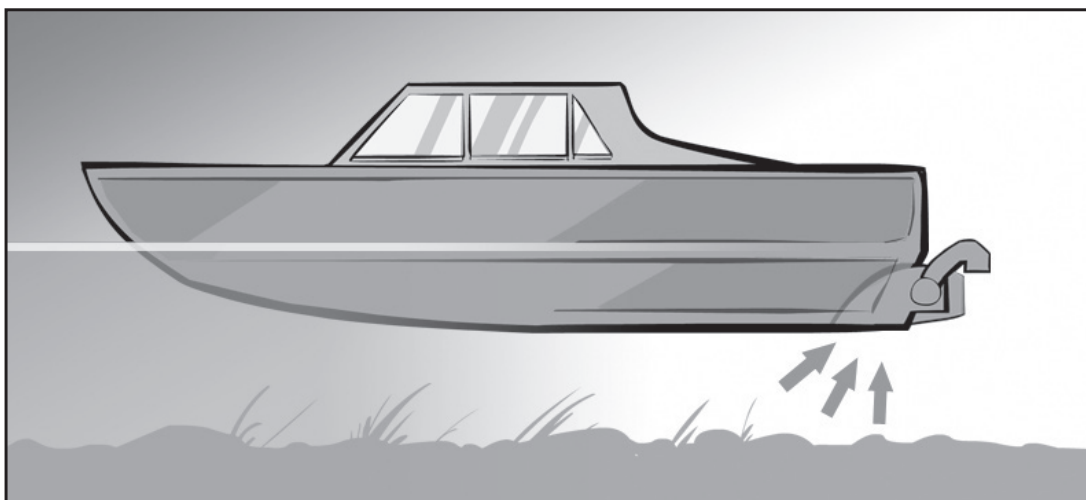

Figure 2.3-1

2.4. Operating in Reedy Water

At planing speeds, a jet boat usually crosses reed fields without difficulty. In difficult conditions however, clogging may be possible. In boats equipped with a gear box, cleaning the intake duct is easy because at reverse gear, a back flow is created in the duct.



THE JET HAS BEEN DESIGNED TO RUN ON REVERSE GEAR ONLY MOMENTARILY AND ON LOW REVOLUTIONS. A TOO HEAVY LOAD ON REVERSE GEAR CAN LEAD TO JAMMING OF THE IMPELLER OR BREAKING DOWN OF HYDRAULICS!

The sleeve shown in figure 2.4-1 on the axle has a left-handed threading. If the engine is run at too high revolutions on reverse gear, the sleeve may loosen and the impeller may get stuck against the duct walls.

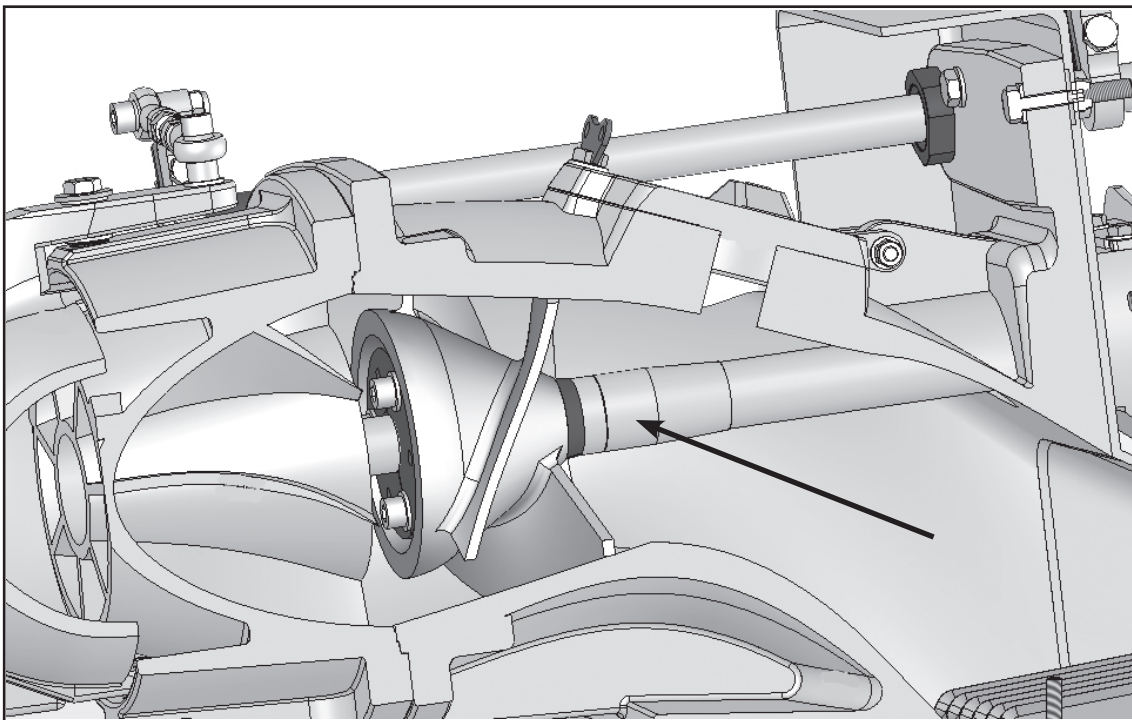

Figure 2.4-1

If clogging occurs on a boat that does not have a gear box, the following procedures are recommended:

1. Stop the engine. This causes the extraneous objects in the grass rake simply to drop off.
2. Let the engine run on high revolutions for a few times. This often sucks the extraneous objects through the jet and cleans it.
3. If the boat is moving forward, raise the boat speed as much as possible and then shut down the engine. The speed of the boat often sweeps the grass rake clean.
4. Drive the boat on reverse as fast as possible. As the boat moves astern, shut down the engine and move the deflector control lever to forward position. This causes water to flow backwards through the jet and usually opens any blockage whatsoever.

With these simple instructions it is possible practically without exception to clean the jet even after the boat has stopped completely in reedy water.

Unlike with other propulsions, in boats equipped with the jet the engine stops very rarely as a result of a reed blockage.

If the measures mentioned above are not of help, the propulsion is equipped with an inspection hatch (figure 2.4-2), through which the blockage can be seen and removed.



Figure 2.4-2

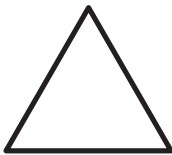

Remember to close the hatch! The wing screw is tightened by hand!

2.5. Dry running

The jet may be run by the engine even out of the water, because the bearings are greased and oiled. This is a significant benefit in comparison to water-lubricated bearings, which do not sustain dry running well. During dry runs, a temporary water inlet must be arranged for the motor sea water cycle to cool the engine.

2.6. Cavitation and Ventilation

2.6.1. Cavitation

The most common malfunction in water jet propulsion units manifests as cavitation. Engine overdrive and stopping of thrust are signs of this.

Cavitation is a phenomenon in which the water pressure decreases locally in such an extent that water vaporizes on the surface of the impeller blade, creating steam bubbles. The bubbles move on the surface of the blade and when they reach a higher pressure area they collapse. Cavitation incurs considerable reduction in capacity and damages the impeller.

Usually the cause is the reduction of pressure in the whole intake duct, which is induced by a blockage.

Cavitation can often be heard as a rumbling sound.

Any factor that hinders the flow of water in the jet increases the chance of cavitation.

If cavitation is apparent, the following things should be checked.

Check through the inspection hatch that:

1. The grass rake (figure 2.6.1-1) is not clogged (by grass, reed, plastic, stones etc.).

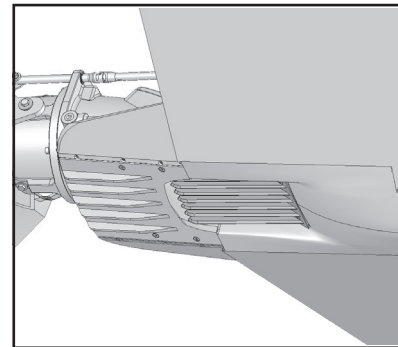

Figure 2.6.1-1

2. There are no extraneous objects in the stator or nozzle unit or the impeller (figure 2.6.1-2) (rope, reed entangled in the drive shaft, stones in the outlet port)

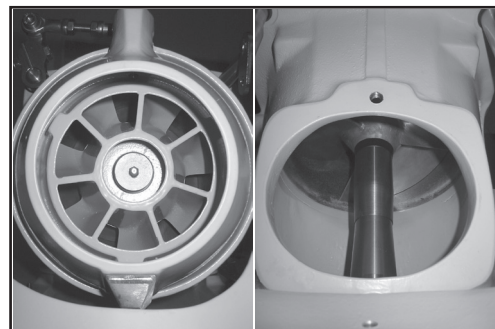

Figure 2.6.1-2

3. The impeller (figure 2.6.1-3) is not damaged. It should be smooth and it should not have any sharp cuts.

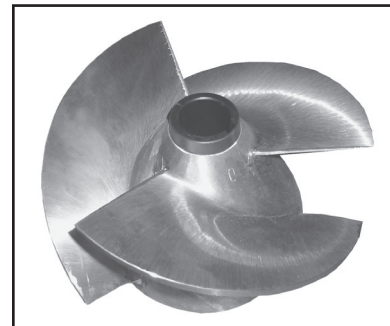

Figure 2.6.1-3

If the boat runs slowly even though the engine runs on high revolutions, find out the cause.

2.6.2. Ventilation

Ventilation produces similar symptoms as cavitation but is caused by different reasons.

Ventilation is created when air gets to drift into the intake duct. The air causes the impeller to lose grip and the thrust weakens. Ventilation can be heard as a similar sound as cavitation.

Ventilation can be caused e.g. by the following things:

- The inspection hatch cover is open or a seal is damaged.
- The installation height of the jet is wrong, air is allowed to pass along the surface of the cavitation plate into the intake duct.
- During installation, places accordant with the instructions have not been sealed.

3. Functions

3.1. Transmission

The jet takes its propulsion power from a petrol or a diesel engine. The most common way to transmit the power is through a 1:1 gear box, but direct drive is also possible and functional. The greatest benefits of a gear box are a real neutral gear and an intake duct backflush.

In the direct drive or so-called bobtail installation it is commendable to use a flywheel adapter provided by the engine manufacturer. It protects the flywheel from mechanical damages and e.g. corrosion.

The *auxiliary shaft* which is connected between the jet and the engine usually depends on the boat manufacturer. If necessary, the jet manufacturer supplies the auxiliary shaft with the propulsion unit. It is also possible to get instructions and recommendations from the manufacturer on which auxiliary shaft to use. In the end, the shaft manufacturer gives instructions on the installation and maintenance of the shaft. Below is a list of example shafts which have been used with the jet.

1. Constant velocity shaft

- Joint structure based on balls rolling on a spherical surface.

2. Cardan shaft

- Joint structure based on pivoted grids.

3. Silent block shaft

- Joint structure based on an elastic rubber element



THE AUXILIARY SHAFT MUST ABSOLUTELY BE OF HIGH ENOUGH QUALITY AND PROPERLY BALANCED. A POOR SHAFT CAN CAUSE EXCESSIVE DAMAGE TO THE PROPULSION UNIT.

THE ALIGNMENT OF THE AUXILIARY SHAFT MUST BE KEPT ACCURATE. IT MUST BE CHECKED AT LEAST ONCE EVERY DRIVING SEASON (YEAR).

3.2. Bearing

The jet's bearing is very simple (figure 3.2-1). There are bearings at both ends of the direct shaft. The structure of the front bearing (A) is receptive to axial pressure. In addition, at the front end there is the supporting bearing (B) of the coupling flange and the auxiliary shaft.

Rolling type bearing is used at the front end and slide bearings are used at the rear (C).

Both bearings are stock grease lubricated. It is possible to install a water lubricated bearing at the rear end.

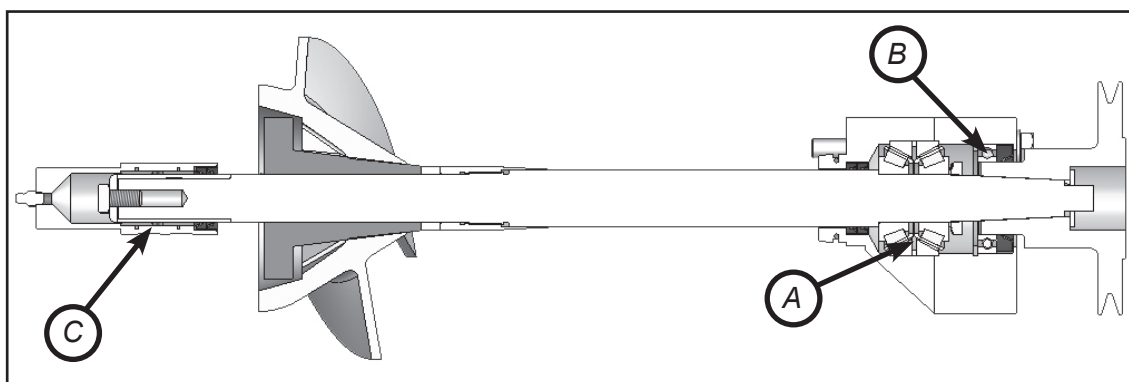

Figure 3.2-1

Lubricate front bearings every 50 hours or twice a year at minimum. The bearings are lubricated through the hose in the engine room.

The boat should be lifted out of water when lubricating the rear bearings. It is advisable to add grease to the rear bearings whenever the boat is lifted out of water. At minimum, however, this should be done every 100 hours or twice a year.

3.3. Control System

3.3.1. Electronic Reversing Deflector Control System

The system is available for models AJ 160, AJ 180 and AJ 185.

The main components that the system consists of are #1 a control lever (potentiometer), #3 an electronics unit and #4 a spindle motor. See figure SE-01 in Appendixes.

The electronics unit changes the position of the lever into a signal to to the spindle motor.

The repair and adjustment instructions for the system can be found in Repair Manual 1.

3.3.2. Hydraulic Reversing Deflector Control System

The system is available for AJ 230. It includes a rotary valve which simplifies the system considerably.

The reversing deflector is controlled (cf. figure 3.3.2-1) mechanically with a cable (A) which operates the valve regulator (B).

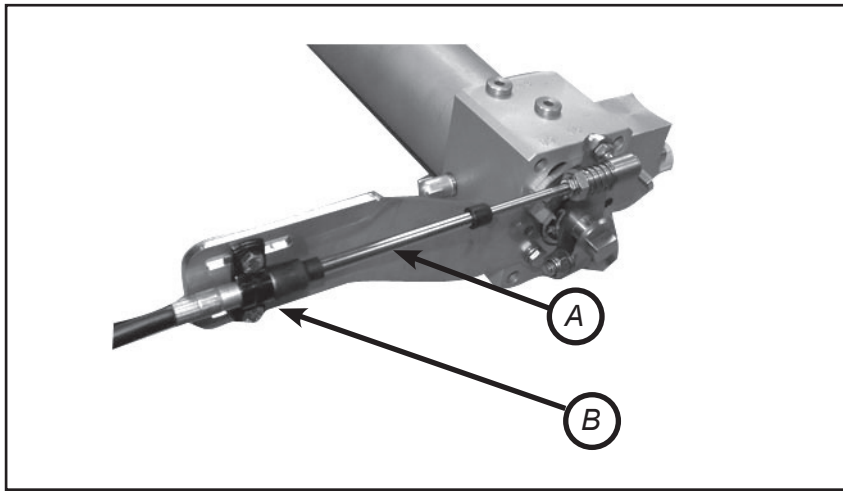

Figure 3.3.2-1

The cylinder gets its power from the oil pump which has been integrated in the propulsion unit.

In a stock delivery, the system does not include a control lever or a cable, so their type varies depending on the boat manufacturer. However, the different types of systems have the following things in common:

- The operation of the deflector must be separate from the throttle and the gear.
- The stroke length of the cylinder is always the same.
- The incoming direction of the cable can be chosen freely.

The *oil circulating in the system must be cooled* in order to prevent excessive heating. This is done with a separate heat exchanger or a possible cooler in the engine.



IF THE OIL IN THE SYSTEM IS NOT COOLED, THE MANUFACTURER IS NOT RESPONSIBLE FOR POSSIBLE DAMAGES WHICH DERIVE DIRECTLY OR INDIRECTLY FROM THE OIL OVERHEATING!

An extra cooler must be installed in the following cases:

1. If there is no cooler in the engine.
2. If the cooler in the engine is reserved, e.g. for cooling the transmission oil.

In the figure below 3.3.2-2 is a system in which the cooling water comes from the jet (see next chapter). The system can consist of different looking components depending on the boat manufacturer. What is essential is the correct order of the components. Notice especially the cooler's place after the filter. A system equipped with a separate raw water intake pump has the same main components.

If it is necessary to add oil to the system, add it in the oil reservoir. There is a dipstick on the reservoir cap with markings for maximum and minimum level. See picture 3.3.2-2.

The type of oil to be used has been described in appendix 4.

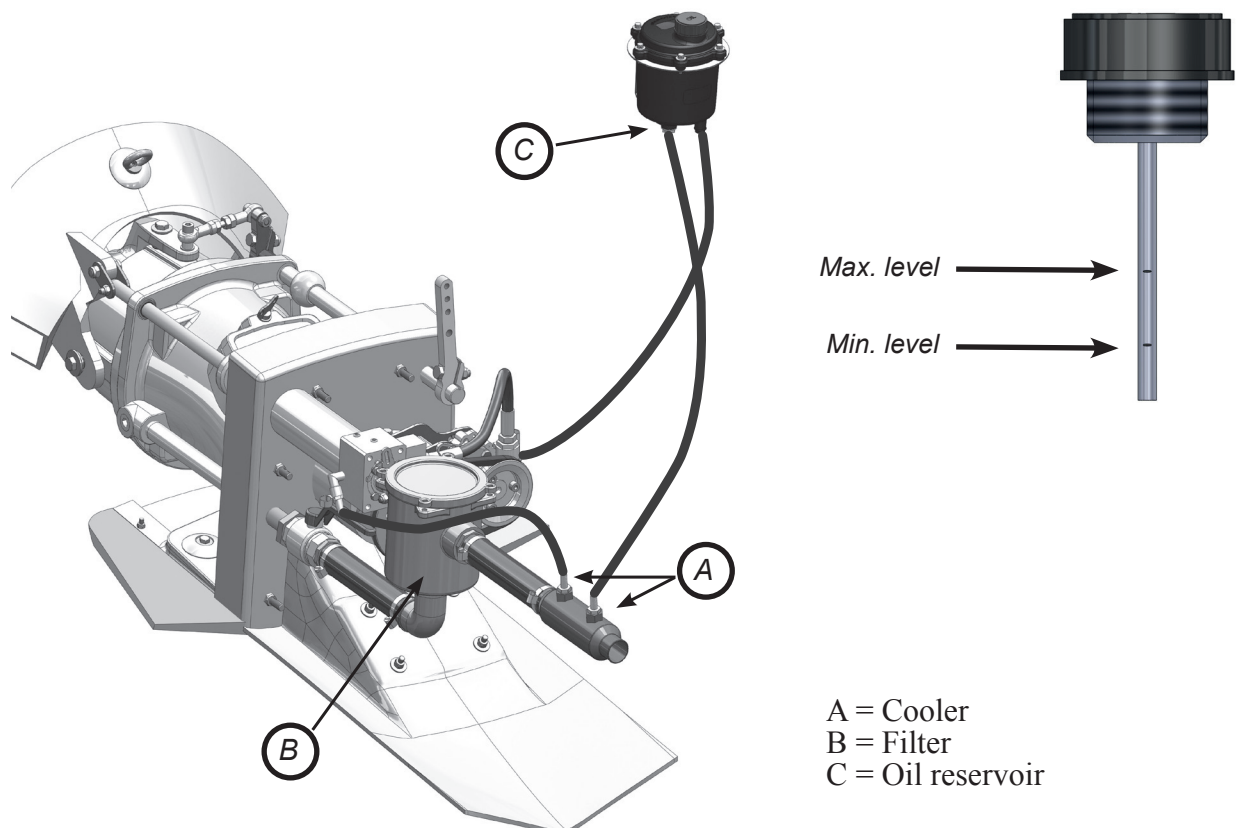

Figure 3.3.2-2

3.4. Raw Water Cooling

The jet comes complete with the possibility to connect the engine cooling water (cf. Figure 3.4-1). The engine does not need a separate water pump. However, if the cooling water is taken with a separate pump, the jet's raw water line is stoppered.

At the beginning of the line, there must be a tap with which the line can be shut temporarily for example during cleaning of the filter or other maintenance.

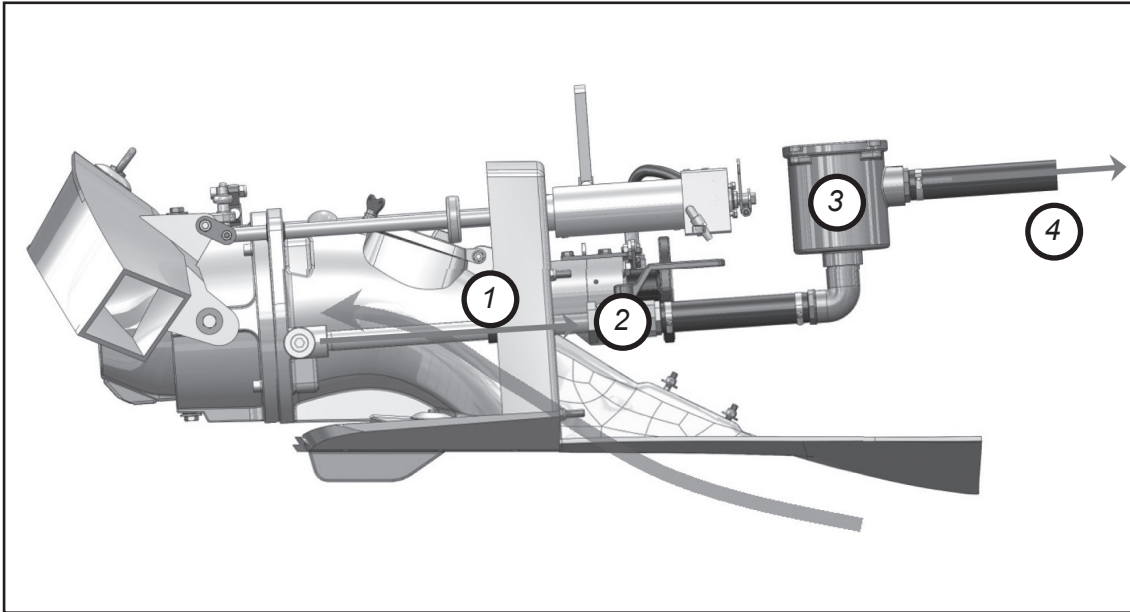

Figure 3.4-1

1. Raw water connector (G 3/4")
2. Tap
3. Filter
4. Raw water intake

3.5. Corrosion Protection

3.5.1. Cathodic Protection

The raw materials used for manufacturing the jet parts are mainly aluminum, acid-proof steel, and plastic.

Materials that have different electrochemical properties can form a so-called galvanic couple while they are in electrolytic fluid (salt water). A galvanic couple forms an electric circuit, because the materials have different inherent voltages. This in turn leads to electron movement and corrosion of the weaker material. Cathodic protection is used to try and prevent the propagation of galvanic corrosion. Cathodic protection means introducing into the same circuit a third material, the electrochemical properties of which are weaker.

The jet is protected from galvanic corrosion with passive cathodic protection. Every critical aluminum casting has its own zinc anode. In figure 3.5-1 are shown the places of the anodes.

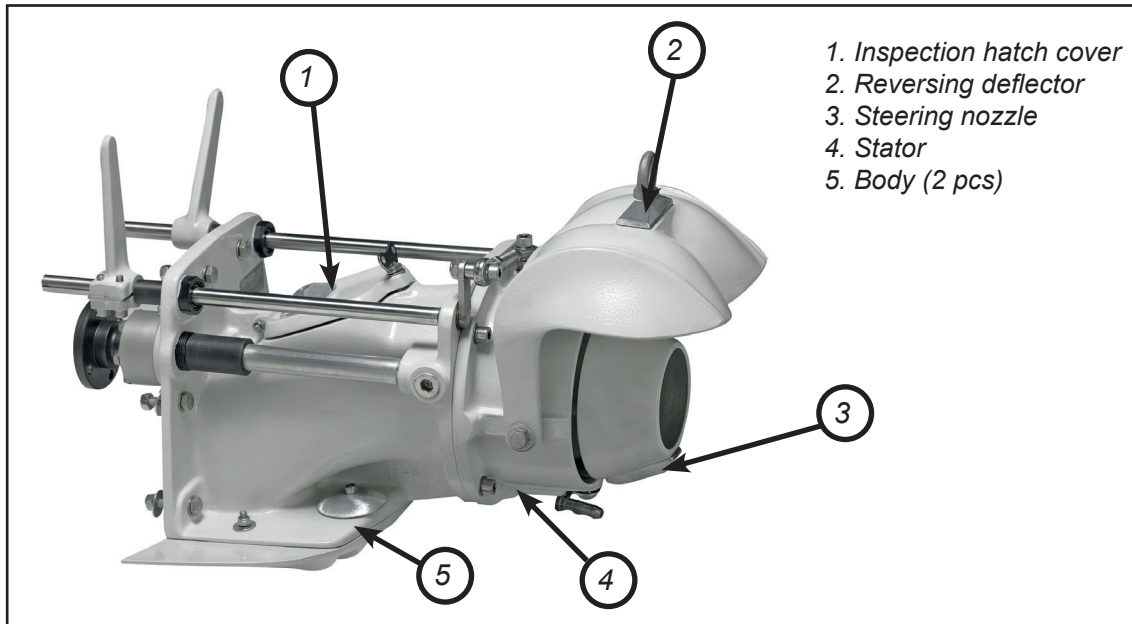

Figure 3.5-1

3.5.2. Painting

The aluminum castings have also been protected by painting. Painting efficiently prevents the propagation of various forms of corrosion e.g. pit corrosion.

Bare aluminum is liable to corrosion in difficult conditions. This is why it is important to carry out touch-up painting if paint comes loose and aluminum is exposed. Touch-up painting can be done in various ways. What is important is that the paints used are suitable for aluminum and that the paint manufacturer's instructions are followed during painting.

If the boat is going to be used in waterways where the growth and sticking of organisms around the boat's bottom and the propulsion unit is heavy, the propulsion unit can be painted with antifouling paint after installation. Generally speaking, antifouling paints are based on various soluble substances, for example copper. Because the propulsion unit is made mainly of aluminium, copper forms a highly unfavourable galvanic couple with the propulsion unit. The aluminium starts to corrode because it functions as an anode.



IF COPPER BEARING ANTIFOULING PAINT IS USED FOR PAINTING THE PROPULSION UNIT, THE RESULT WILL BE HEAVY CORROSION AND DESTRUCTION OF THE PROPULSION UNIT. DO NOT USE ANY OTHER ANTIFOULING PAINTS FOR PAINTING THE PROPULSION UNIT EXCEPT THOSE INTENDED FOR ALUMINIUM SURFACES!

Instead, a boat bottom made of reinforced plastic can be painted using copper bearing antifouling paint. In this case, leave a 50mm unpainted area around the propulsion unit in the stern and on the bottom of the boat. See picture 2.3-1.

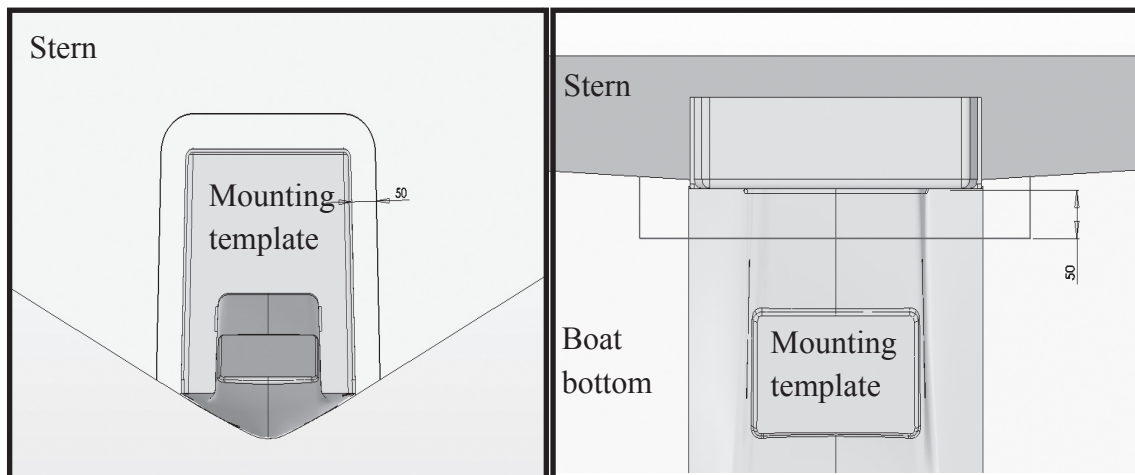

Figure 3.5.3.-1

4. Maintenance

4.1. Tools

The following items are included in the tool kit delivered with the propulsion unit if ordered separately:

- Wrench	10 mm	- Allen wrench	6 mm
- Wrench	13 mm	- Allen wrench	8 mm
- Wrench	17 mm	- Knife	
- Allen wrench	5 mm	- Universal pliers	

Most of the maintenance and repair procedures can be carried out with these tools.

4.2. Periodical Maintenance

The jet is designed and manufactured to be as simple as possible. This is why the need for maintenance is low and maintenance can be carried out on shore.

4.2.1. Washing the Jet

Every time the boat is lifted out of the water, it is advisable to wash it with *fresh water*. This clears possible salt accruals and impurities, which leads to the reduction of corrosive effect due to conditions.

4.2.2 Lubricating the Bearings

4.2.2.1. Lubricating the Front Bearing

The lubrication of the front bearing is carried out from the engine compartment side. To facilitate greasing, there is a hose with a grease nipple at one end connected to the bearing housing. The end of the hose can be attached in the loose space so that using the grease gun is easy.

Excess grease exits the bearing housing automatically. When lubricating, only add 4-5 injections of grease with the grease gun.

The lubrication interval for the bearing is 50 hours or twice a year at minimum.

4.2.2.2. Lubricating the Rear Bearing

It is easiest to carry out the lubrication of the rear bearing when the boat is out of the water, but it can also be done while the boat is in the water. The lubrication is carried out through the steering nozzle from the nipple in the middle of the stator (figure 4.2.2.2-1).

Excess grease exits the bearing housing automatically. When lubricating, only add 2-3 injections of grease with the grease gun.

The lubrication interval for the bearing is 50 hours or twice a year at minimum.

The rear end bearing supports the shaft and centers it in respect of the duct. This is why excessive wearing of the bearing affects the behaviour of the impeller. When the bearing has been worn enough, excess vibration builds up in the unit and “clinking” can be heard from the impeller. In this case the impeller wears also and its efficiency is reduced.

A worn bearing should be replaced with a new one when the aforementioned symptoms appear.



Figure 4.2.2.2-1

Technical specifications for the lubricant greases:

- lithium soap and a thickener with EP additives
- mineral oil as a base oil
- NLGI class 2
- operating temperature range – 25...130°C
- continuous operating temp. min. 75°C

Example greases:

- Würth Multi-Purpose Grease III
- FAG Multi2
- FAG Load 220
- Mobil XHP 222
- Neste Allrex EP2
- Shell Retinax Grease EP2

4.2.3. Lubricating the Control System

The joints and shaft bushings that belong to the control systems are essentially maintenance-free, but lubrication prolongs their operating life. Below (figure 4.2.3-1) is a list of objects, in which water-proof vaseline is added in connection with maintenance. When the plastic bearings of the joints wear and gaps are created, they must be replaced.

1. Shaft bushing in the stern

2. Shaft bushings in the rear flange

3. Pivoting of the reversing deflector on both sides of the stator

4. Pivoting of the nozzle on both sides of the stator

Figure 4.2.3-1

If the boat has two propulsion units, the propulsion unit is equipped with a different kind of reversing deflector. Figure 4.2.3-2 shows the joints of this kind of deflector. The lower joint is located underneath a zinc anode.

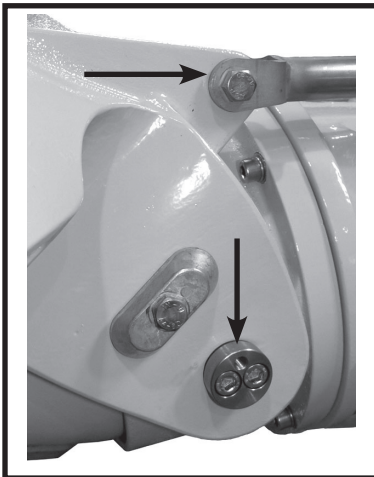

Figure 4.2.3-2

4.2.4 Changing the Zinc Anodes

The jet is protected with passive cathodic protection. The functioning of the zinc anodes is crucial from the point of view of corrosion. The zinc anodes must be changed when they have worn down to half of their original size. Every aluminum component has been protected separately with a zinc anode. The places of the anodes are described in chapter 3.5.1.

4.2.5. Adjusting the Impeller

Depending on driving conditions, the impeller wears, and a gap develops between the duct wall and the tip of the blade. When it expands enough, the jet's performance decreases. By adjusting the impeller, the operating life can be prolonged considerably.

The adjustment of the impeller should be done whenever it is necessary, but checking must be done at least once a year.

Adjusting the impeller is done by removing the impeller and reinstalling it. See next chapter.

4.2.6. Checking the Seals

The seals to be checked are e.g. the O-ring seal of the inspection hatch (A) and the sealings of the steering shaft bushings (B) (figures on the side). When the inspection hatch seal leaks, it causes ventilation and the sealings of the steering shaft bushings cause water to leak in the bilge.

If water gathers in the bilge, the cause for this must be determined immediately and the possible leak must be repaired. Water can damage e.g. the starter motor.

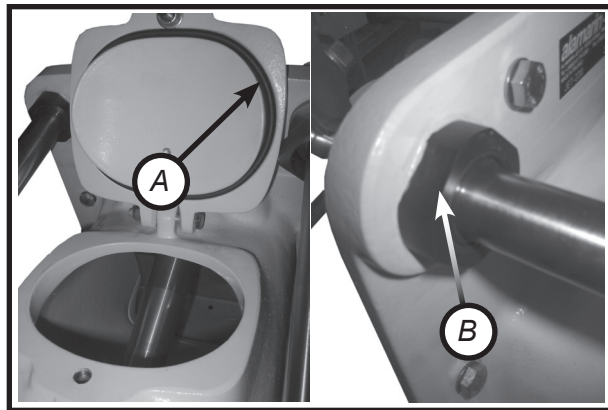

Figure 4.2.6-1

4.2.7. Maintenance of the Hydraulic System

The reversing deflector hydraulic control system requires maintenance as follows:

- checking the oil level
- checking the condition of the V-belt and replacing it if necessary
- checking the condition of the hoses and replacing them if necessary

The Maintenance and Repair Table gives detailed instructions for checking different targets.

Service and Maintenance Chart

	daily	weekly	monthly	every 6 months	yearly
Hydraulic reversing deflector operating system					
hydraulic oil amount		X			
possible leaks (hoses, couplings)		X			
cable fastening			X		
test run and accuracy of reversing deflector movement			X		
tightness of v-belt			X		
condition of spare v-belt				X	
general technical condition				X	
Engine raw water cooling system					
if cooling water from jet					
possible leaks (hoses, couplings)		X			
function of valve (if mounted)			X		
possible blocks in system			X		
Reversing deflector					
zinc anode (1 pcs)				X	
tightness of bolts			X		
paint				X	
general technical condition				X	
Body of the jet					
zinc anodes (2 pcs)				X	
tightness of bolts				X	
paint				X	
general technical condition				X	
cavitation plate's technical condition and paint				X	
Stator					
zinc anode (1 pcs)				X	
tightness of bolts				X	
paint				X	
no blocks in stator intakes				X	
condition of intakes				X	
general technical condition				X	
Steering nozzle and steering system					
zinc anode (1 pcs)				X	
function of steering nozzle and steering system			X		
tightness of bolts			X		
technical condition of control shaft and levers			X		
steering nozzle paint				X	
general technical condition				X	

	daily	weekly	monthly	every 6 months	yearly
Jet inlet duct					
cleanness of inlet surfaces (no marine growth etc.)				x	
Front bearing					
Lubrication			x	x	
tightness of bolts				x	
general technical condition of bearing				x	
End bearing					
Lubrication			x	x	
general technical condition of bearing				x	
Impeller					
allowance of impeller				x	
technical condition of impeller blades				x	
tightness of adjuster sleeve				x	
tightness of bolts				x	
technical condition of impeller mounting cone				x	
technical condition of impeller housing				x	
Main shaft					
general technical condition					x
condition of shaft sleeve (part no 23028)					x
technical condition of jet flange					x
tightness of intermediate shaft fastening bolts				x	x

All maintenance that has been done to the propulsion unit can be entered in the Maintenance Log. The Maintenance Log is Appendix 1.

4.3. The Impeller

The impeller usually wears on the outer edge of the blades. It operates in a cone-shaped space and its position can be adjusted in the direction of the shaft in accordance with the blade wear.

The gap between the outer edge of the blades and the cone should be as small as possible to achieve best efficiency. (Factory installation gap 0.2 mm).

The longitudinal position of the impeller in the duct reveals its power demand. The deeper the impeller sits, the less power it takes from the engine, because the diameter of the impeller is smaller. The pitch and the length and number of blades naturally also affect the power demand.

The size marking of the impeller can be found both at the front and rear end (figure 4.3-1). It can be seen through the inspection hatch and by removing the stator.

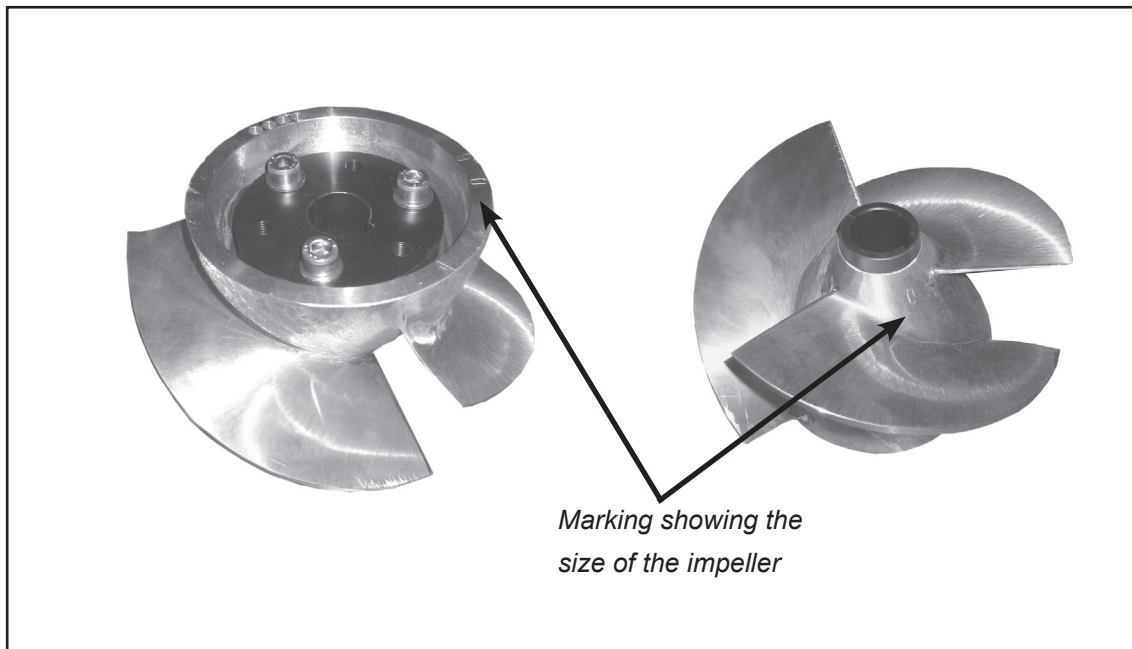

Figure 4.3-1

The condition of the front edge of the impeller blades is important. A damaged front edge causes cavitation.

The front edge can be repaired by carefully hammering the marks caused by bigger stones and grinding them smooth. The front edge must not be sharpened, it must be left about 2mm thick and rounded

$r = 1 \text{ mm}$.

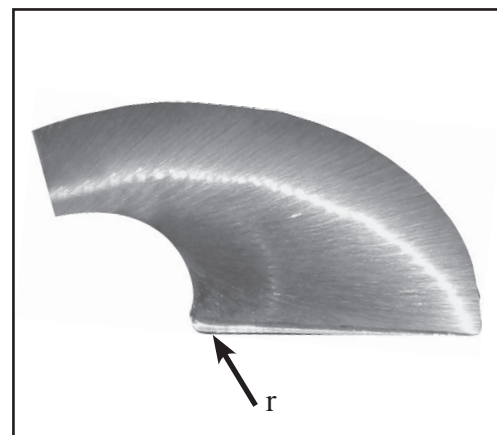

Figure 4.3-2

You can also return the impeller to the factory for checking and repairing.

If you suspect that there is a malfunction in the impeller, do as follows:

1. Shut down the engine and open the inspection hatch.
2. Check that nothing is blocking the intake duct.
3. Check the impeller visually. Notice especially the gap between the outer edge of the blade and the duct wall.

4. If there is no apparent fault, the boat must be lifted out of the water for closer inspection.
5. Remove the impeller. See section Removing the Impeller below.
6. Check the impeller more closely. You can always ask the importer or manufacturer for instructions.

4.3.1. Removing the Impeller

1. Remove the joint between the reversing deflector and the hydraulic cylinder by opening the bolt marked by the arrow (A) (AJ 230). In models that do not have a hydraulic reversing deflector control, the loop joint (B) which connects the reversing deflector and the steering shaft, is removed.

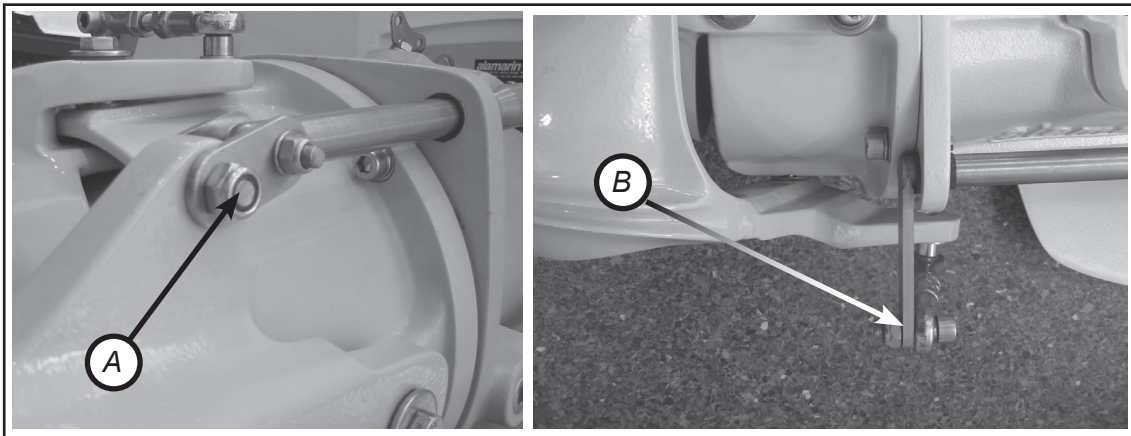

Figure 4.3.1-1

2. Remove the joint between the steering nozzle and the steering shaft (figure 4.3.1-2).



Figure 4.3.1-2

3. Open the fastening bolts (4 pcs) of the stator. *After this, the stator, the deflector and the nozzle come off as a whole.* (In figure 4.3.1-3 the reversing deflector has been removed for clarity).

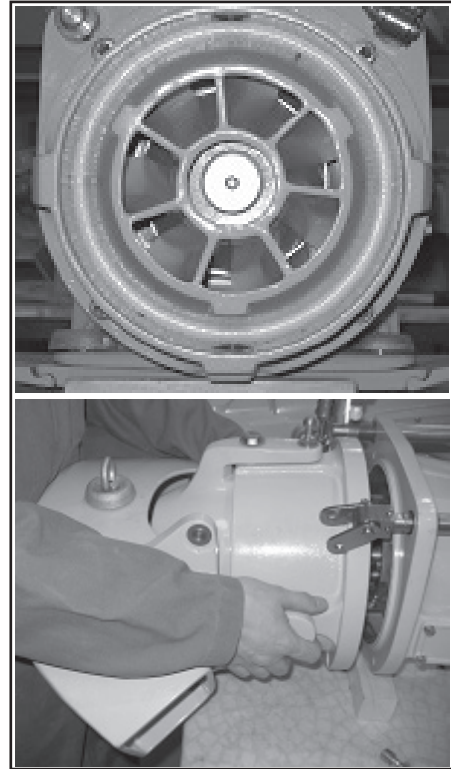

Figure 4.3.1-3



The fitting of the stator and the hull of the propulsion unit with each other is tight. You can help the detachment by cranking with a screwdriver.

4. Loosen the impeller's fastening bolts (figure 4.3.1-4) and completely remove one of them. Screw it in the adjacent threaded hole in line with the wedge groove and tighten carefully. The plastic fastening cone is released and the impeller can be pulled off the shaft.

If the fitting is very tight, multiple bolts are used as help.

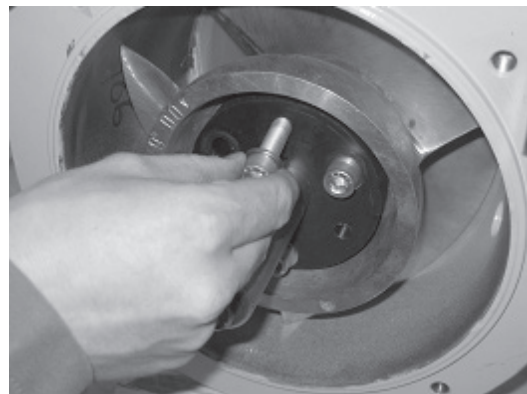

Figure 4.3.1-4

4.3.2. Fitting the Impeller

1. Screw the adjuster sleeve (A) and the possible additional ring on the shaft. The sleeve has a left-handed threading.

Set the wedge (B) in the groove reserved for it.

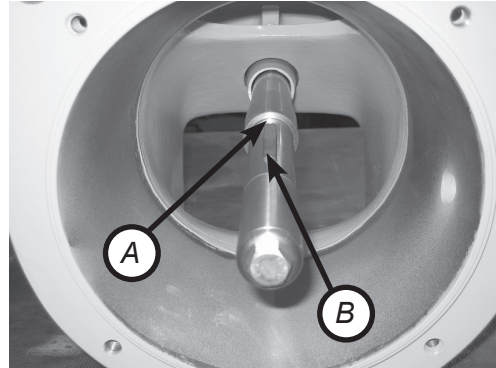

Figure 4.3.2-1

2. The place of the fastening cone wedge groove is marked on the impeller with a line. Set the cone so that the wedge groove is aligned with the line as in figure 4.3.2-2.

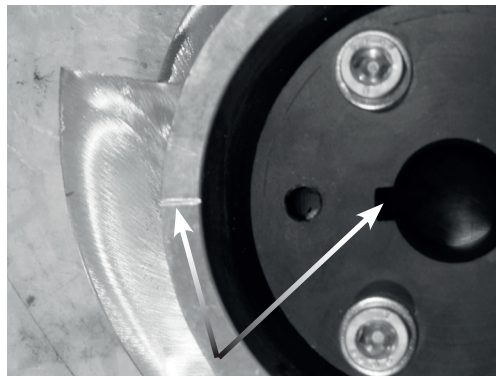

Figure 4.3.2-2

3. Place the impeller on the shaft along with the cone. Tighten the screws finger tight.
4. Push the impeller as far in the intake duct as it goes (B).



BE CAREFUL NOT TO LEAVE YOUR FINGERS BETWEEN THE IMPELLER AND THE CONE! Use the working position (A) shown in figure 4.3.2-1!

Tighten the screws to a torque of 20 Nm.

Screw the adjuster sleeve through the inspection hatch so that it sits tightly against the impeller's plastic cone. If the adjusting sleeve is left loose (B), the impeller gets stuck in the duct cone. Reference C shows a correctly tightened sleeve.

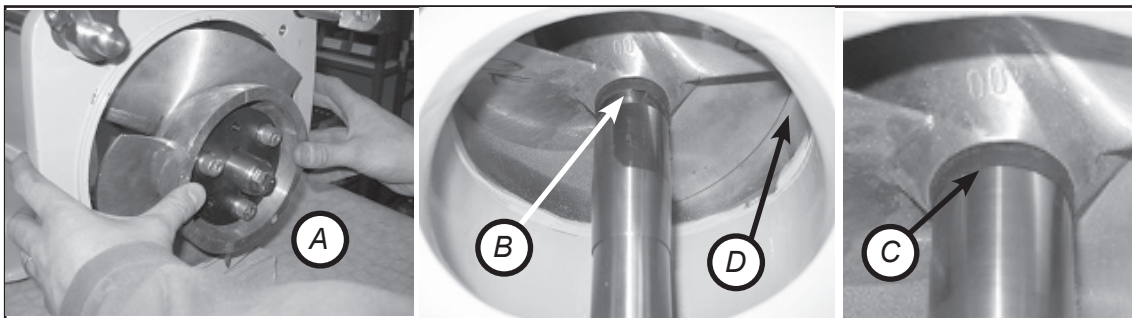

Figure 4.3.2-1

There can be a gap of 0.2 mm between the impeller blade and the cone (D). During installation, the lower edge lies on the cone and there can be a slightly bigger gap at the upper part of the impeller due to the weight of the impeller and the axle. This gap disappears when the stator finally centers the shaft.

Too wide a gap between the cone and the impeller blade leads to loss of power.

If the impeller does not rotate properly after the installation, open the impeller screws, pull it slightly outwards, and tighten the screws.

5. Close the inspection hatch.
6. Install the reversing deflector, the steering nozzle and the stator in place as a whole in a reverse order than when removing. The tightening torque for M10 bolts is 50Nm and 80Nm for M12 bolts.

Appendix 1: MAINTENANCE LOG

MAINTENANCE LOG

Commissioning
Made by:
Date:

Service

Commissioning
Made by:
Date:

Service

Commissioning
Made by:
Date:

Service

Commissioning
Made by:
Date:

Service

Commissioning
Made by:
Date:

Service

Commissioning
Made by:
Date:

Service

Appendix 2: SE-01

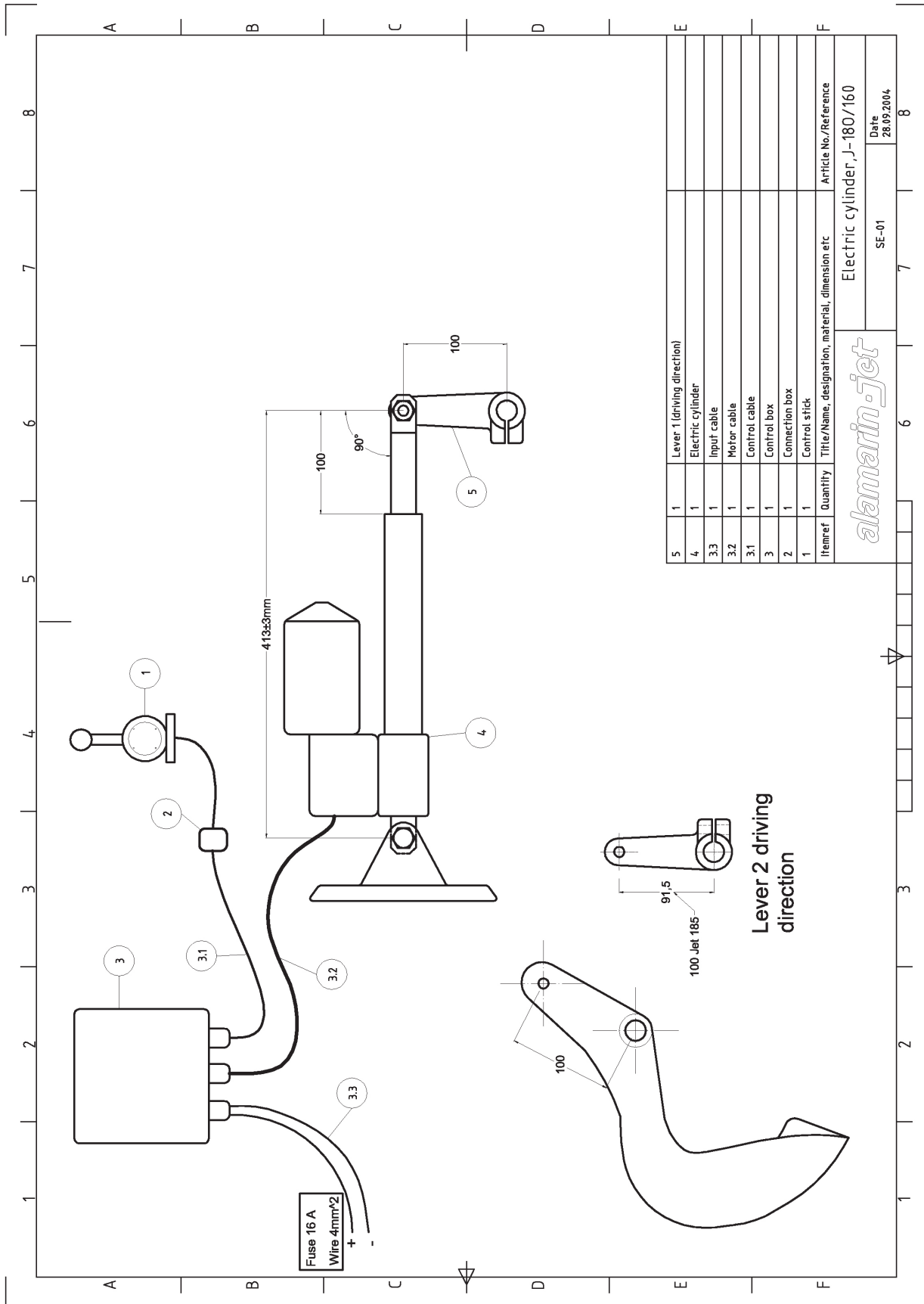

Appendix 3: SE-02

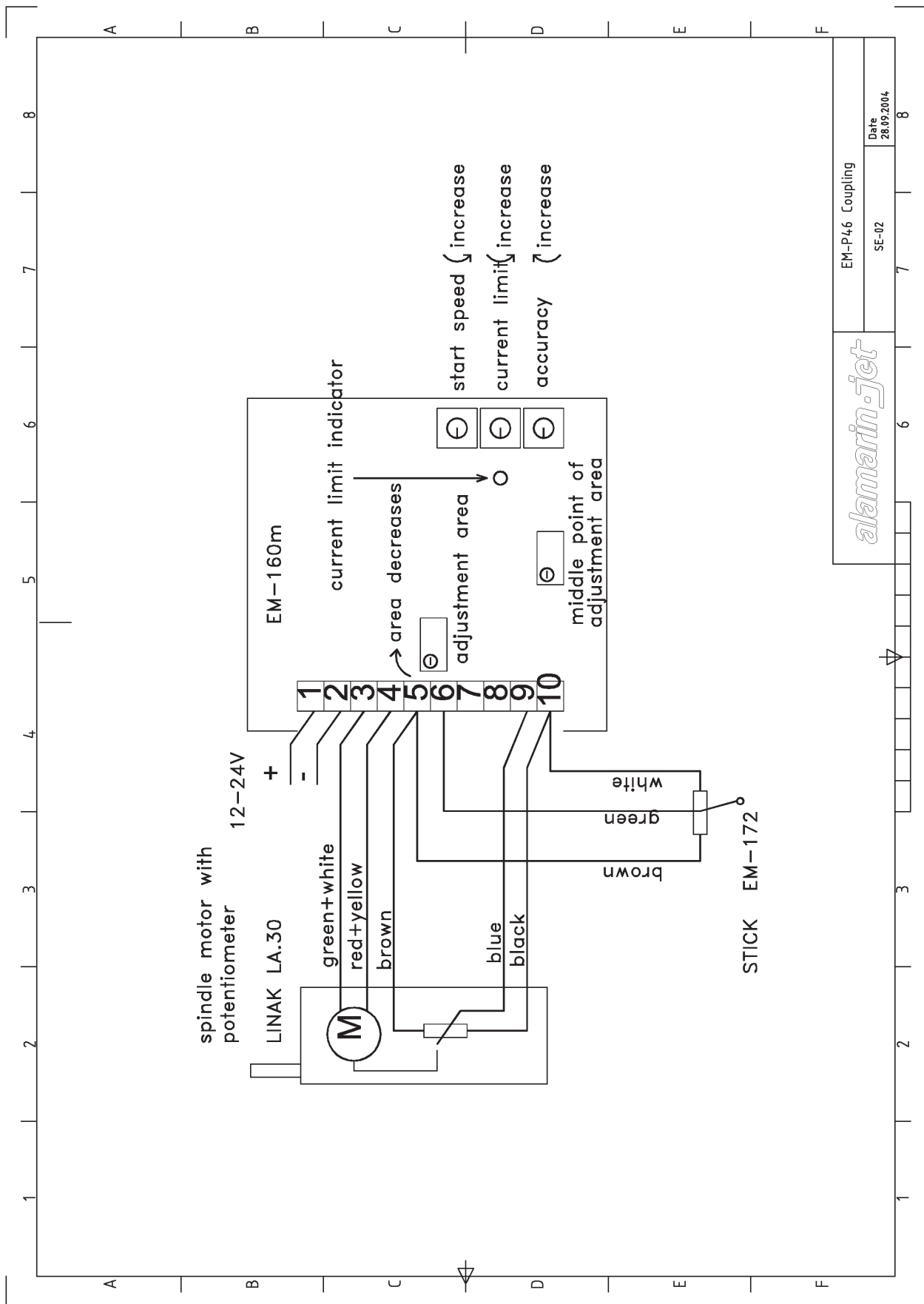

Appendix 4: RECOMMENDED GREASES AND OILS AND TIGHTENING TORQUES OF THE SCREWS

1. The grease used for lubricating the bearings of the propulsion unit must meet the requirements below.

- lithium soap and a thickener with EP additives
- mineral oil as a base oil
- NLGI class 2
- operating temperature range -25...130°C
- continuous operating temperature min. 75°C

The following grease brands are recommended as an example:

Würth Multi-Purpose Grease III, FAG Multi2, FAG Load 220, Mobil XHP 222, Neste Allrex EP2, Shell Retinax Grease EP2.

A grease that has equivalent properties to those mentioned above can also be used for lubricating.

2. The operating hydraulic system of the reversing deflector has been designed operate with automatic transmission oil.

Kinematic viscosity 40°C	33...36 mm ² /s
Kinematic viscosity 100°C	7.1...7.7 mm ² /s
Viscosity index	min 170
Density 15°C	0.835...0.890 g/cm ³
Pour point	max. 42°C
Flashpoint	min. 180°C

The following oil brands are recommended as an example:

Mobil ATF 320, FormulaShell ATF DEXRON III, Neste ATF-X, BP Autran DX III

3. The tightening torques in the table below must be used when tightening the screws on the propulsion unit. The values 8.8, 10.9, and 12.9 signify the strength classes of the screws. The strength class of the A4-80 acid-proof screw corresponds to a 8.8 class screw.

Tightening torques of the screws			
Thread	Tightening torque (Nm)		
	8.8	10.9	12.9
M5	5.5	8.1	9.5
M6	9.6	14	16
M8	23	34	40
M10	46	67	79
M12	79	115	135
M16	145	215	250

A suitable thread locking compound for all purposes is one of medium strength, for example Loctite 242 or similar.

Appendix 5: EXPLODED VIEWS

When delivering this manual in paper form, the manufacturer has added to the following pages the exploded views of the propulsion unit model with which the manual is delivered. In the electronic version the exploded views as a separate file.

Appendix 6: WARRANTY & OWNERSHIP

**Warranty & Ownership
Registration Card**

Alamarin-Jet Owner Identification Card
 Complete the Warranty registration card and send the factory copy to:
 Alamarin-Jet
 Tuomisentie 16
 FI-62300 Härmä
 Fax: +358 10 7745 269
 sales@alamarinjet.com

Owner's Name	email	
Address		
City	State	Zip
Date Of Commissioning		
Alamarin Jet Model	Serial Number(s)	
Project / Vessel		
Contact Name	Signature	



Dealer Record Card

Alamarin-Jet Owner Identification Card
 Alamarin-Jet
 Tuomisentie 16
 FI-62300 Härmä
 Fax: +358 10 7745 269
 sales@alamarinjet.com

Owner's Name	email	
Adress		
City	State	Zip
Date Of Commissioning		
Alamarin Jet Model	Serial Number(s)	
Project / Vessel		
Contact Name	Signature	

ALAMARIN-JET

www.alamarinjet.com