

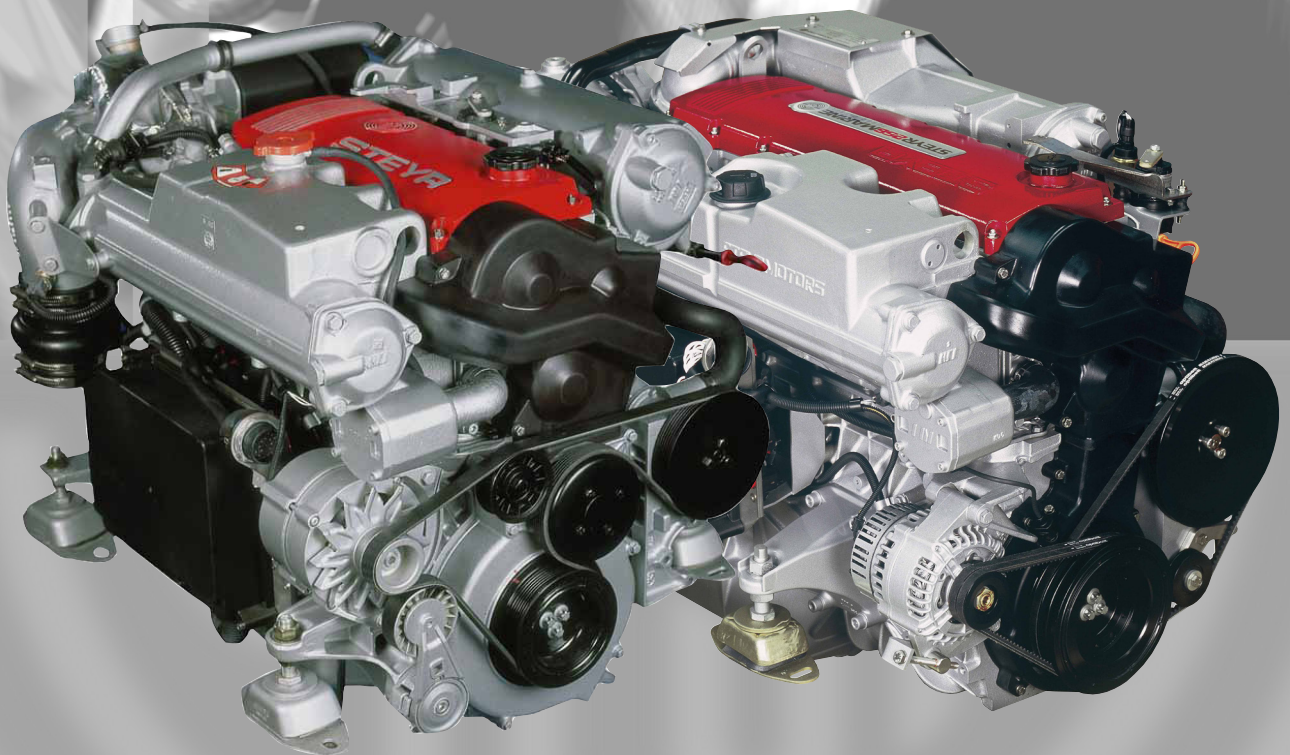

# STEYR MOTORS MARINE ENGINES

## 4 CYLINDERS + 6 CYLINDERS



# OPERATION, MAINTENANCE AND WARRANTY MANUAL

P/N Z001022/0 10<sup>th</sup> Edition July 2011



## WELCOME ABOARD



Congratulations on your decision of choosing a STEYR MOTORS marine engine for your boat, and we hope you will enjoy it.

**STEYR MOTORS GmbH** has developed a high-speed diesel engine with two stage high-pressure fuel injection specifically for the marine environment. STEYR MOTORS marine engines are designed to be adapted to various propulsion systems.

To come up to your expectations, please study thoroughly this manual for your new **STEYR MOTORS marine engine** to get sufficient information on its operation and handling and to permit an optimal use of the various built-in functions.

With kind regards,  
**STEYR MOTORS GmbH**



**STEYR MOTORS GmbH**  
After Sales Service

Im Stadtgut B1  
4407 Steyr, Austria

[www.steyr-motors.com](http://www.steyr-motors.com)

**YOUR STEYR MOTORS  
MARINE DEALER**

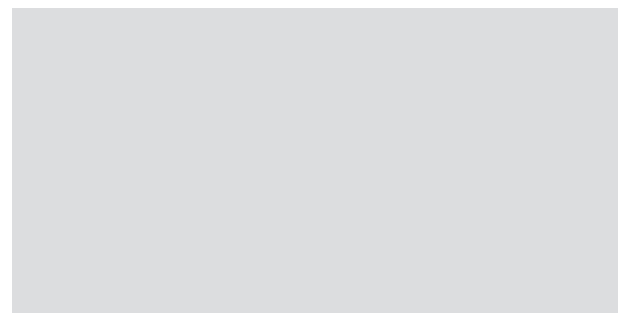

10<sup>th</sup> Edition, July 2011

**P/N Z001022/0**

## How to use this manual

### Table of Contents

#### GENERAL PART

PAGE 5 – 12

This section contains user instructions and general notes on safety for STEYR MOTORS marine engines.

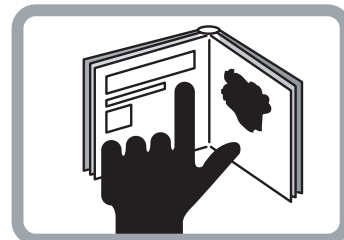

#### START-UP AND FUNCTIONS

PAGE 15 – 40

This section contains brief instruction, function description and normal operation, as well as correct start-up and handling of STEYR MOTORS marine engines.

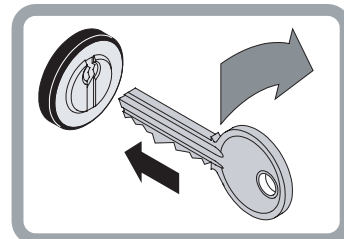

#### FUEL AND LUBRICANTS

PAGE 41 – 44

This section defines the requirements as to fuel and lubricants for STEYR MOTORS marine engines.

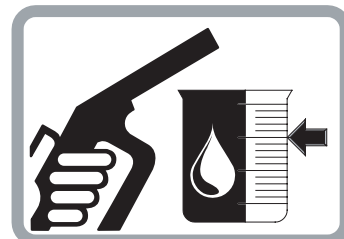

#### TECHNICAL DATA

PAGE 45 – 62

This section contains technical data and product description of STEYR MOTORS marine engines.

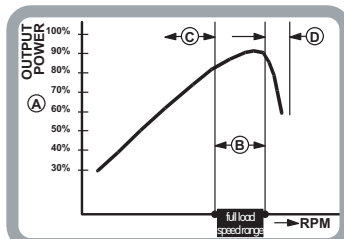

#### MAINTENANCE, TROUBLE SHOOTING

PAGE 63 – 88

This section contains instructions for required maintenance and notes on the fault finding on your STEYR MOTORS marine engine.

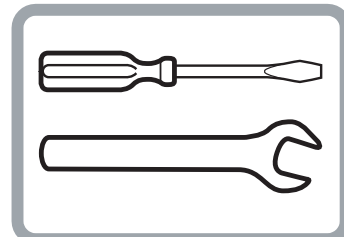

#### DEALER'S RESPONSIBILITIES

PAGE 89 – 106

This section contains instructions for installation acceptance tests, propeller selection, removal from service, start-up after storage, adequate disposal and dealer's test list.

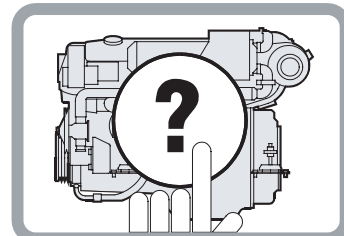

#### WARRANTY, DISTRIBUTORS

PAGE 107 – 118

This section contains warranty conditions (services and obligations) for owners and manufacturers of STEYR MOTORS marine engines.





## GENERAL PART

General .....	6
Marine Engine Overview .....	7
Product References, Illustrations and Specifications .....	8
Insurance .....	8
Stolen Unit .....	8
Owner Identification Card .....	8
Installation and pre-delivery inspection log .....	9
Dealer Service – Maintenance .....	9
Illustration Symbols .....	9
Repair Service .....	10
Replacement Parts .....	10
Before Casting Off .....	10
Engine Submersion .....	11
Bottom Painting .....	11
Boat Bottom .....	11
Boating Responsibilities .....	12
Safety .....	12
Symbols .....	13

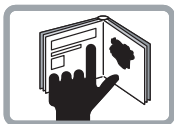

## General

This **MANUAL** is published by STEYR MOTORS GmbH with the main intention to provide information in form of technical data and know-how based on our experience in the marine diesel engine business, which will enable you, after thorough study to operate and check the engines on your boat, ensuring their operating safety, reliability and long service life.

### CE conformity:

Under regular maintenance, as described in the chapter “Maintenance and Trouble Shooting”, the exhaust gas emission levels adhere to the limits stipulated, for pleasure boat operation, throughout the life time of the engine.

All warranty claims to be addressed to your local STEYR MOTORS Marine Dealer.

(We have to rely on your assistance however) For continuous improvement with regard to form and contents of the information required.

Your comments on the following questions would be much appreciated

- Which descriptions or terms are not understandable?
- Which enlargements or complements do you suggest?
- Where did content-related mistakes slip in?

Please address your comments and ideas to your STEYR MOTORS – Marine Dealer.

Since this manual covers the whole family of STEYR MOTORS marine engines, differing sections are marked as follows:

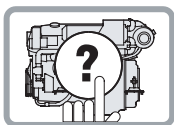

**1.)**

*whole page applies to all engines*

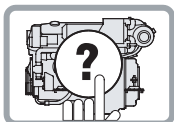

MO144K33

**2.)**

*whole page applies to specified engine types only*

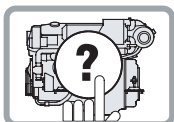

GENERAL

**3.)**

MO114K33	<3,700 rpm	<i>whole page applies in principle for all engine types, but different data, e.g. technical data, is marked.</i>
MO166K28	<2,600 rpm	
MO236K42	<4,000 rpm	



## MARINE ENGINE OVERVIEW

MAKE		STEYR MOTORS M 16 TCAM					
engine type	displacement [cm <sup>3</sup> ]	rated power [kW]	exhaust back pressure [mbar]	tolerance exhaust back pressure ± [mbar]	charge-air pressure [mbar]*	charge-air pressure tolerance ± [mbar]	max. intake depression @ rated power [mbar]
MO156K25	3,200	110	150	±50	2,400	+50/-100	50
MO126K25	3,200	88	150	±50	2,000	±100	50
MO196K35	3,200	140	150	±50	2,500	±100	50
MO236K42	3,200	170	150	±50	2,800	±100	50
MO256K43	3,200	184	150	±50	2,900	±100	50
MO256H45	3,200	184	150	±50	2,900	±100	50
MO286H43	3,200	205	150	+0/-50	3,100	±100	50
MO306H43WJ	3,200	215	150	+0/-50	3,300	±100	50

MAKE		STEYR MOTORS M 14 TCAM					
engine type	displacement [cm <sup>3</sup> ]	rated power [kW]	exhaust back pressure [mbar]	tolerance exhaust back pressure ± [mbar]	charge-air pressure [mbar]*	charge-air pressure tolerance ± [mbar]	max. intake depression @ rated power [mbar]
MO114K33	2,100	81	100	±50	1,900	±100	50
MO144V38	2,100	106	100	±50	2,280	±100	50
MO144M38	2,100	106	100	±50	2,250	±100	50
MO164M40	2,100	120	100	±50	2,740	±100	50
MO174V40	2,100	125	150	+0/-50	3,100	±50	50

MAKE		STEYR MOTORS M 14 TCM					
engine type	displacement [cm <sup>3</sup> ]	rated power [kW]	exhaust back pressure [mbar]	tolerance exhaust back pressure ± [mbar]	charge-air pressure [mbar]*	charge-air pressure tolerance ± [mbar]	max. intake depression @ rated power [mbar]
MO84K32	2,100	55	100	±50	1,900	±100	50
MO94K33	2,100	66	100	±50	1,900	±100	50

MAKE		STEYR MOTORS M 14 NAM					
engine type	displacement [cm <sup>3</sup> ]	rated power [kW]	exhaust back pressure [mbar]	tolerance exhaust back pressure ± [mbar]	charge-air pressure [mbar]*	charge-air pressure tolerance ± [mbar]	max. intake depression @ rated power [mbar]
MO54NA33	2,100	40	80	+0/-50	–	–	50

\* at standard reference conditions according to ISO 15550



## Product References, Illustrations and Specifications

When reference is made in this manual to a brand name, number, product or specific tool, an equivalent product may be used in place of the product referred to unless specifically stated otherwise. Equivalent products which are used must meet all current local regulations and standards to avoid hazards.

Some countries may apply additional internal regulation. Please follow their advices appropriately, example:

Austria:	Bundesamt für Schifffahrt
Sweden:	Navigation Office
Finland:	Navigation Office
Norway:	DNV = Det Norske Veritas
USA:	USCG = United States Coast Guard
USA:	ABYC = American Boat Yacht Council
USA:	NMMA = National Marine Manufacturers Association
England:	LR = Lloyds Register of Shipping
France:	BV = Bureau Veritas
Germany:	GL = GERMANISCHER Lloyd
Italy:	RINA = Registro Italiano Navale

All information, illustrations and specifications contained in this manual are based on the latest product information available at the time of printing. **STEYR MOTORS GmbH reserves the right to make changes at any time, without notice, to specifications and models and also to discontinue models, as well as the right to change specifications or parts at any time without incurring any obligation to equip same on models manufactured prior to date of such change.**

Continual accuracy of this manual cannot be guaranteed.

All illustrations used in this manual may not depict actual models or equipment and are intended as representative views for reference only.

## Insurance

Insurance on your **STEYR MOTORS Marine Engine** and boat should be obtained as soon as practical for protection against loss by fire, theft, etc. Consult your local insurance agent.

## Stolen Unit

The model and serial numbers on your engine are important for you. As to the location of these important numbers, refer to **Model and Serial Numbers** in the section Technical Data.

Record each of these numbers in the spaces provided at the end of this manual and on a separate sheet. Store the separate sheet in a safe place other than your boat.

In case of theft, report the model and serial numbers to your local authorities and your insurance agent.

## Owner Identification Card

When you purchases your boat, your dealer was obliged to issue an owner identification card for your **STEYR MOTORS Marine Engine**.

This owner identification card gives proof and is to be submitted in case of warranty claims.





## Installation and pre-delivery inspection log

Your STEYR MOTORS Marine dealer is also obliged to complete the installation and pre-delivery inspection log (Chapter “DEALER’S RESPONSIBILITIES”). Required tests and measurements are to be carried out accordingly.

A copy of the installation and pre-delivery inspection log and engine registration card are to be forwarded to STEYR MOTORS GmbH.

## Dealer Service – Maintenance

**NOTE:** Please do not forget to have confirmed in your manual that the installation and maintenance have been carried out in accordance with the guidelines.

This is also an opportunity to clarify with your STEYR MOTORS marine dealer possible questions arisen during the first running hours on your boat, and to establish a service- and maintenance routine.

Services will be performed by **STEYR MOTORS Marine Dealers** at local rates.

Costs for service material to be paid by the owner.

## Illustration Symbols

	Refer to the photograph or drawing described in that paragraph.
	Refer to specific items or features described in the text and illustrated on the photograph.
	Refer to the general subject of the text.
	Refer to an item or feature not clearly visible on the photograph.



## Repair Service

All repair works on your **STEYR MOTORS marine engine** should be carried out by a licensed STEYR MOTORS Marine Dealer with his professional knowledge, trained staff and special-purpose tools to solve all occurring problems. Preferably, all work on your **STEYR MOTORS marine engine** should be carried out by the STEYR MOTORS Marine Dealer that sold the equipment to you – he knows you and the equipment.

If problems occur during a trip, bring your **engine** to the next **STEYR MOTORS Marine Dealer**. Information on Dealers and Distributors can be found at the end of this manual.

## Replacement Parts

Your **STEYR MOTORS Marine Engine** was designed to operate in a marine environment use STEYR MOTORS original replacement parts.

## Before Casting Off

Check the weather report, wind and water conditions. Tell someone where you are going to and when you expect to arrive or return.

### Recommended Minimum On-Board Tools

Screwdriver Set  
Metric Socket Set  
Metric Allen Key Set  
Metric Spanner Set  
long nose pliers

lubrication oil spray  
12-volt pilot lamp  
flashlight  
insulating tape  
sharp knife

### Recommended Minimum On-Board Spare Parts

propeller and small parts for propeller mounting  
fuel filter  
impeller for raw water pump

fuses  
bulbs  
sealing compound

These lists represent a suggested **MINIMUM**, and are not intended to cover all boats or possible boating conditions.

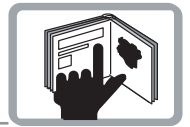

## Engine Submersion

Remove engine from water as quickly as possible and contact your local STEYR MOTORS Marine dealer for service.

It is imperative that your dealer removes all water from the engine and immediately relubricates all internal parts. Electrical devices must be replaced. Delay in completing these actions may allow extensive engine damage.

Frequently check engine compartment for excessive water accumulation; water depth in bilge should be kept well below flywheel housing. Engine compartment must enable proper venting to avoid condensation to build up on inner surfaces.

## Bottom Painting

If your boat is in water where marine growth is a problem, the use of an antifouling paint will reduce the growth rate.

\* Tin base antifouling paint (TBTA or TBTF) is recommended where its use is permitted.

\* Copper base antifouling paint may be used, but will require more frequent inspection and replacement of sacrificial anodes. **DO NOT PAINT** any part of the drive unit with copper base antifouling paint.

**NOTE:** Painting the drive unit with copper base paint will accelerate galvanic corrosion.

\* Vinyl-butyl base antifouling paint is a recommended alternative.

\* **DO NOT USE** any graphite base antifouling paint.

**NOTE:** Never paint anti-corrosion anodes, or their effectiveness will be lost. See your STEYR MOTORS Marine contract partner for an antifouling paint that is suitable for your area.

## Boat Bottom

The condition of the boat bottom can affect your boat's performance. Marine growth, present in fresh water as well as salt water, will reduce boat speed. A boat bottom with evidence of marine growth causes a reduction in top speed of 20 percent or more. Periodically clean the bottom of your boat following the manufacturer's recommendations.



## Boating Responsibilities

As a boat owner, you have certain responsibilities to others. Be sure that all operators read this manual.

You are legally responsible for all occupants of your boat. Instruct at least one of your passengers in the basic fundamentals of handling your boat in case of an emergency. Show all hands the location of emergency equipment and how to use it. You are required by law to have one locally approved life jacket for each person aboard, plus one approved throwable device for man overboard protection.

Learn the waterway rules of the location in which you are going to operate your boat. Navigable waterways are controlled by Federal regulations while inland lakes are controlled by local jurisdictions. Obey these regulations to protect yourself, your passengers and fellow boating enthusiasts.

Thoroughly familiarize yourself with weather station warning system signals and waterway traffic signs.

Contact your local Coast Guard station and take advantage of their seasonal boat inspections and training courses.

## Safety

This manual contains certain information related to the personal safety of you the operator, your passengers and bystanders.

The Safety symbol  **ATTENTION:** appears next to important information to prevent you and others from being hurt.

The symbol **NOTE:** appears next to important information to keep machinery from being damaged.

Observe all notes and safety warnings contained in this manual.

## WARNING

























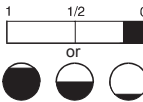







### CALIFORNIA: PROPOSITION 65 WARNING

Diesel engine exhaust and some of its constituents are known to the state of California to cause cancer, birth defects, and other reproductive harm.



## Symbols

Certain symbols or combinations of symbols may appear on your **STEYR MOTORS Marine Engine** or on its accessories. It is very important that you understand their meaning or purpose. If any symbol is not clearly understood, see your DEALER.

<b>“Safety Warning” Symbols</b>		
 Means risk of <b>SERIOUS</b> injury is present. Follow instructions in the Operation, Maintenance & Warranty Manual before using motor or accessory.	 Means place shift control in <b>NEUTRAL</b> before starting motor. Follow instructions in Operation, Maintenance & Warranty Manual before starting motor.	 Indicates that <b>ELECTRICITY</b> of more than 50 volts is present.
 Indicates that contents are under pressure.	 Identifies poisonous material.	 Indicates a potential fire hazard.
<b>“Position Indicator” Symbols</b>		
 Indicates upward movement. Example: While boat is at planing speed, activating trim switch to raise the bow of the boat.	 Indicates downward movement. Example: While boat is at planing speed, activating trim switch to lower the bow of the boat.	 Indicates gear shift control positions: <b>FORWARD, NEUTRAL and REVERSE</b>
<b>“Condition” Symbols</b>		
 Identifies the meter which indicates accumulative running hours of engine.	 Identifies the meter which indicates battery voltage or amperage.	 Identifies the meter which indicates engine speed expressed in revolutions per minute.
 Identifies battery or a meter which indicates status of battery-generator charging system.	 Indicates the amount of liquid in tank.	 Identifies the meter which indicates engine coolant pressure.
 Identifies the meter which indicates engine coolant temperature.	 <b>FILTER:</b> Identifies a device which removes contaminants from engine's oil system.	 Identifies the meter which indicates the pressure of engine's lubricating system.
<b>“Functional Description” Symbols</b>		
 <b>FILTER:</b> Identifies a device which removes contaminants from fuel.	 Identifies the <b>EMERGENCY IGNITION CUT-OFF SWITCH.</b> Emergency engine stop.	 <b>FUSE:</b> Identifies a device which protects the electrical system from overload.
 Identifies the negative ground or negative voltage connection.	 Identifies engine drain plugs and fittings.	 Identifies the operating device for starting the motor.
 Identifies the <b>STOP SWITCH.</b> It may also identify <b>STOP</b> position of the throttle control.		
<b>“Instructional” Symbols</b>		
 Indicates <b>FUEL</b> is to be used or <b>FUEL</b> is present.	 Means read your Operation, Maintenance & Warranty Manual before operating the product. It contains information or instructions vital for operation of product.	 Indicates areas to be lubricated.
 Indicates <b>OIL</b> is to be used or <b>OIL</b> is present.	 <b>ENGINE OIL FILL:</b> Location for introduction of oil into the engine.	 Indicates lubricating oil used in transmissions.



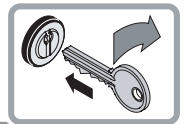

## START-UP AND FUNCTIONS

Before Starting .....	17
Starting the Engine .....	18
Stopping the Engine .....	18
Starting the Engine (for SOLAS only) .....	19
Stopping the Engine (for SOLAS only) .....	19
Run In Procedure After Major Overhaul .....	20
Definitions .....	20
Procedure, Work steps .....	20
Engine Break-In procedure .....	21
First Ten Hours .....	21
Final Ten Hours of Break-in .....	21
Operation after Break-In .....	22
Shifting .....	23
Remote Control Operating Instructions .....	24
How to Shift and Control Speed .....	25
Fuel Economy .....	25
Gear Box – Information .....	25
High Altitude Operation .....	25
Instrument panel .....	26
Instrument panel, standard .....	26
Instrument indication during normal operation .....	27
Instrument panel (for SOLAS only) .....	28
Instrument indication during normal operation (for SOLAS only) .....	29
Emergency cut off switch (Lanyard) .....	30
Warning lights and audible alarm .....	31
Electronic Engine Control Unit (ECU) .....	32

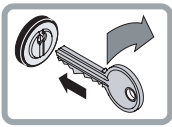

## START-UP AND FUNCTIONS

Diagnostic system .....	33
Twin Installations .....	34
Optional Propellers .....	34
Propellers .....	34
Propeller Torque .....	35
Propeller care .....	35
Water Jet .....	35
Operating Procedure for Freezing Temperatures .....	35
Salt Water Operation .....	35
Fuel Pump .....	36
Fuel System Checks .....	36
Fuel Contamination .....	36
Cooling System (Function Description) .....	37
Electrical Equipment .....	38
Alternator .....	38
Battery .....	38
Circuit Breakers .....	39
Inversion Switch .....	40
Interrupt crankshaft housing ventilation .....	40
Instrument Panel .....	40
Dry Operation .....	40



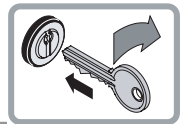

## Before Starting

Familiarize yourself with the handling of the boat, in particular how to use transmission, and then proceed as follows:

1. Check the bilge for excessive water accumulation. Always keep the bilge clean and dry. Never allow the water level in the engine compartment to exceed the bottom of the oil pan. If water accumulation is unavoidable, install a bilge pump with an automatic control switch.

**NOTE:** The water level in the boat's engine compartment will increase when the boat is operated at a high incline before planing speed is reached. Excessive water accumulation in the engine compartment/bilge may cause engine failures.

2. Open the raw water intake valve.

**NOTE:** Operate the engine only while the raw water supply is assured or the cooling system is equipped with a flushing device. The raw water pump will be damaged and/or the engine will overheat if operated without cooling water.

3. Open the fuel stop valve.

**NOTE:** Only start the engine when a bubble-free fuel supply is guaranteed. Prior to first start-up of the engine (after installation, after storage etc.), purge the fuel system by "ignition ON" for 6 x 10 sec.

4. Check the operating levels of:

- \* coolant
- \* oil
- \* hydraulic oil
- \* transmission oil
- \* fuel

5. Control of electric system:

- \* Charge and charge state of battery.

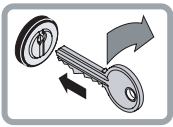

## Starting the Engine

Starting procedure for the **STEYR MOTORS marine engine** is the same for both cold and warm engines. The engine control unit **automatically regulates the fuel supply and the preheating period**, for any given temperature. Therefore, the throttle lever should remain in neutral position.

1. To start the engine, move throttle lever into idle position and gear into neutral position.
2. Turn ignition key into position ignition "ON". An audible alarm will sound and the warning lights are illuminated (temporary), indicating the correct function of the audible and visual warning systems.

**NOTE:** In case of a low temperature start wait until the combined oil pressure/glow plug pre-heating indication light is turned off, before you continue with the start procedure.

3. Turn ignition key into position "**START**" and hold in this position until "**starting**" of engine, but under no circumstances hold in this position for more than ten seconds.  
If engine does not start, release **ignition key** momentarily and repeat **starting procedure**.
4. As soon as engine starts, release ignition key. The audible alarm will stop when normal oil pressure has been reached.

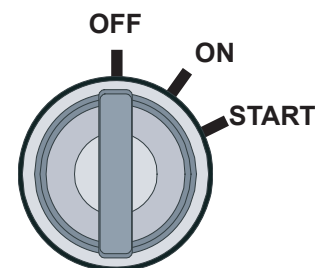
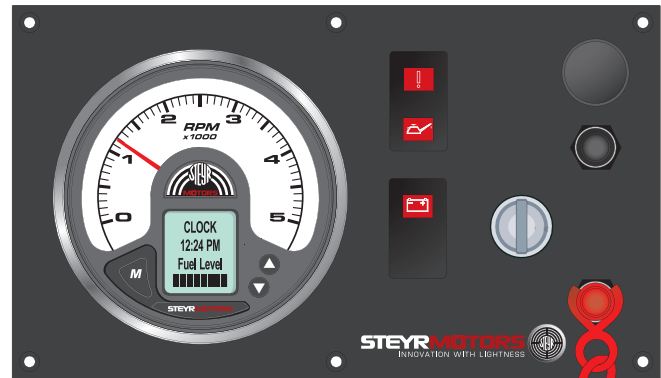

**ATTENTION:** If engine fails to start within one minute and/or repeated attempts, contact your STEYR MOTORS Marine dealer.  
Never turn ignition key to position "START" when engine is running.



## Stopping the Engine

1. Move throttle lever into idle position and gear in neutral position.
2. Cool down the engine.
3. Turn ignition key to OFF position.

**ATTENTION:** Do not stop engine at speeds above idle or "accelerate" engine while turning off ignition. This may result in engine failures.



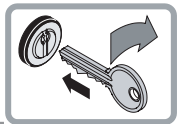

## Starting the Engine (for SOLAS only)

Starting procedure for the **STEYR MOTORS marine engine** is the same for cold or warm operating condition. The engine control unit **automatically regulates the fuel supply and the preheating period**, for any given temperature. Therefore, the throttle lever should remain in neutral position.

1. To start the engine, move throttle lever into idle position and gear into neutral position.
2. Press the **push button for ignition** (ill.F; red) (push button lock in place); An audible alarm will sound and the warning lights are illuminated (temporary), indicating the correct function of the audible and visual warning system.

**NOTE:** In case of a low temperature start, wait until the combined oil pressure/glow plug pre-heating indication light is turned off, then continue with the start procedure.

3. Press the **button START** (ill.G; green) and hold in this position until **“starting”** of engine, but under no circumstances hold in this position for more than ten seconds.  
If engine does not start, release **start – push button** momentarily and repeat **starting procedure**.
4. As soon as engine starts, release start button. The audible alarm will stop when normal oil pressure has been reached.

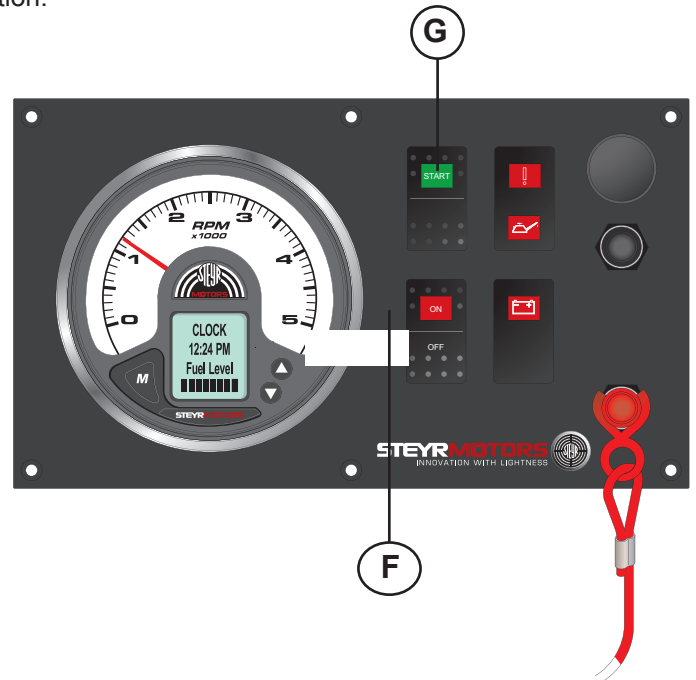

**ATTENTION:** If engine fails to start within one minute and/or repeated attempts, contact your STEYR MOTORS Marine dealer.  
Never push start button when engine is running.



## Stopping the Engine (for SOLAS only)

1. Move throttle lever into idle position and gear in neutral position.
2. Cool down the engine.
3. Press push **button ignition ON/OFF** (ill.F) to disengage from locking position and to shut OFF the engine.

**ATTENTION:** Do not stop engine at speeds above idle or “accelerate” engine while turning off engine. This may result in engine failures.



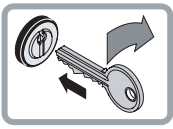

## Run In Procedure After Major Overhaul

The following run in procedure must be used on STEYR MOTORS engines following a major overhaul, where a major overhaul is defined as a replacement of any or all of the following:

Crank Shaft, Piston(s), Con rod(s), Monoblock

### Definitions

- \* Rated speed ... Engine speed with maximum power
- \* Half engine speed ... Half of rated speed

### Procedure, Work steps

#### Preparation

- \* Engine filled with oil and coolant to max. levels
- \* Oil Shell RIMULA ULTRA 10 W 40
- \* Coolant GLYCOSHELL – 50/50 % water/coolant
- \* STEYR MOTORS engine diagnostic tool connected to the ECU

#### Test method

- \* Remove the expansion tank pressure cap for degassing the system
- \* Start the engine
- \* Run at idle speed for 20 min
- \* Stop the engine
- \* Check coolant and oil level, top up to max. level if necessary
- \* Close the expansion tank with the pressure cap
- \* Start the engine
- \* Warm up the engine (~15 mins.)
- \* Run the boat minimum for 4 hrs at no more than half engine speed
- \* Check oil level, top up to max level
- \* Check the error list in the ECU using the diagnostic programme, if no errors continue run in. If errors occurred, contact STEYR MOTORS After Sales department for further decisions
- \* Warm up the engine (~15 mins.)
- \* Run the boat minimum for 2 hrs at no more than 75 % engine speed
- \* Check the service code list in the ECU using the diagnostic program, if no errors continue run in. If errors occurred, contact STEYR MOTORS After Sales department for further decisions
- \* Warm up the engine (~15 mins.)
- \* Start the STEYR MOTORS diagnostic tool data logger
- \* Run the boat minimum for 20 mins. at full rated speed
- \* Stop diagnostic tool data logger and save the file (filename: engine number and date e.g. 68225765\_20080910.dat)
- \* Check the service code list in the ECU. If errors occurred, contact STEYR MOTORS After Sales department for further decisions
- \* Send the data Log file to STEYR MOTORS After Sales department
- \* Check coolant and oil level at cold engine, top up to max. level if necessary
- \* Continue using the engine acc. to STEYR MOTORS Operator Manual

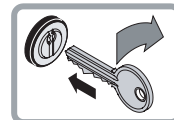

## Engine Break-In procedure

All **STEYR MOTORS Marine engines** have been run for a short period as a final test at the factory. You must follow the Engine Break-In instructions during the first 20 running hours to ensure maximum performance and longest engine life.

**NOTE:** Non-observance of break-in instructions may cause severe engine failure.

### First Ten Hours

**Maximum Engine Speed: 75 % of rated speed**

**Maximum Throttle Position: 75 %**

For the first five to ten minutes of operation, run the engine at low speed (below 1,500 RPM). For the remaining first ten hours of operation, accelerate to bring boat onto plane quickly. After reaching planing reduce throttle to remain at minimum planing. For displacement or semi displacement boats the throttle position of 75 % must not be transcended. Occasionally reduce throttle to idle speed for cooling down.

**ATTENTION:** Warning indication engine over load during break – in via ECU (Engine Control Unit) The ECU monitors, during the first two hours of engine operation, the load on the engine. If the engine is overloaded (during the first 2 hours of running) the “Check Engine Light” will automatically illuminate. If the warning light illuminates (CEL light – ON), the throttle position must be reduced until this signals are extinguish.



### Final Ten Hours of Break-in

**Maximum Short Term Speed: 100 % of rated speed**

**Maximum Short Term Throttle Position: 100 %**

During the final ten hours of break-in, the engine may run at full speed **for five to ten minutes**. The remaining hours should be operated up to 75 % throttle position. For displacement or semi displacement boats the throttle position of 75 % must not be transcended Occasionally reduce the engine speed to cool is down.

**NOTE:** During the break-in period, the engine must not be operated at high rpm for longer periods.

During break-in period, be particularly observant of the following:

- A. Check motor oil level daily. Always maintain oil level in the desired range between the “MIN” and “MAX” marks on dipstick. When refilling motor oil, refer to information “Engine Lubrication – Motor Oil” (page 41).
- B. Check oil pressure control lamp. If the lamp lights up as soon as the boat changes its position (while turning, straightening up the boat or planing), check the oil level in the engine housing by means of dipstick. If necessary, add oil (DO NOT OVERFILL). In case that the oil pressure control lamp is still illuminated with correct oil level, have the engine checked by your STEYR MOTORS Marine dealer as to malfunction of signal or oil pump.

**NOTE:** During normal operation of engine, oil pressure will rise as RPM increases and fall as RPM decreases. In general, oil pressure will be higher with cold engine oil and specific RPM than with hot motor oil.

- C. Check engine temperature indication. Normal operation between 80° – 95°. In case of audible alarm, check coolant level in expansion tank (only with cold engine).
- D. Deviations from normal operating conditions will be indicated by warning lights and audible alarm. As to exact meanings see section Error Indication on Instrument Panel.

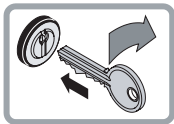

**ATTENTION:** In case of non-observance of break-in instructions, warranty may expire.



**Engine to be filled with recommended oil quality only. See chapter “Engine Lubrication”.**

### Operation after Break-In

The engines specified in this manual are intended to be operated at different speeds and loads, but not allowing full-load of the engine for more than one hour per 12 running hours. Economic driving may be achieved at the following speeds:

MO54NA33	<b>3,000 rpm</b>
MO84K32	<b>3,000 rpm</b>
MO94K33	<b>3,000 rpm</b>
MO114K33	<b>3,000 rpm</b>
MO144M38	<b>3,200 rpm</b>
MO164M40	<b>3,400 rpm</b>
MO174V40	<b>3,400 rpm</b>
MO126M28	<b>2,200 rpm</b>
MO126K25	<b>2,200 rpm</b>
MO156K25	<b>2,200 rpm</b>
MO196M28	<b>2,200 rpm</b>
MO236K42	<b>3,300 rpm</b>
MO256K43	<b>3,600 rpm</b>
MO256H45	<b>3,600 rpm</b>
MO286H43	<b>3,600 rpm</b>
MO306H43W	<b>3,600 rpm</b>

Which will prolong engine life and reduce sound emissions.

When starting a cold engine, always allow the engine to warm up slowly. Never run the engine at full speed until operating temperature is reached. During the first 50 running hours, check the oil level frequently.

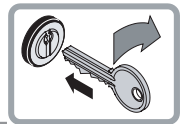

## Shifting

1. If the gear shift mechanism is disengaged, move the control lever to neutral position. The shift mechanism will automatically engage.
2. To go FORWARD – press the neutral lock button if fitted, and move the control lever forward. Throttle movement will begin after forward gear engagement.
3. To go in REVERSE – press the neutral lock button if fitted, and move the control lever backwards. Throttle movement will begin after reverse gear engagement.
4. To go from FORWARD to REVERSE, or REVERSE to FORWARD, always pause at NEUTRAL and allow engine speed to return to idle.
5. After shifting is completed, continue to move the control lever slowly in the desired direction to increase speed.

**NOTE:** A sudden increase in shifting torque on the remote control lever indicates a possible problem in the shifting system. If so, see your STEYR MOTORS dealer as soon as possible for proper diagnosis and and necessary service adjustment. Continued operation under this condition could result in damage to the shifting mechanism.

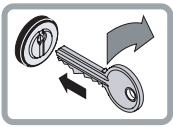

## Remote Control Operating Instructions

**1** Your boat may be equipped with one of the following remote controls:

- \* Single lever control
- \* Dual lever control for twin engines

**NOTE:** If other than STEYR MOTORS matched remote controls are used, follow the manufacturer's recommendation.

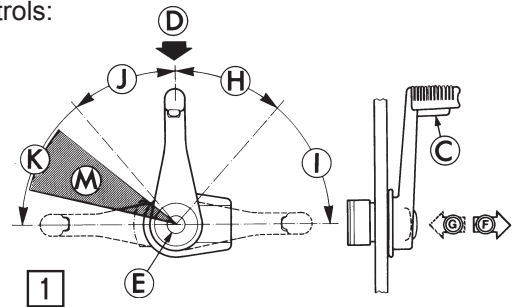

Remote controls have the following important features:

- \* A single lever which allows to select forward or reverse gear, regulate engine speed, and ensure shifting is done at low engine speed.
- \* A start-in-neutral-only feature which will protect you from starting your **STEYR MOTORS Marine Engine** with engaged gears.

The side mount control has a neutral lock button (**C**) located in the control lever which must be pressed to permit shifting from neutral to forward or reverse. The top mount controls do not have a neutral lock, but there is a neutral ratchet position.

### Side Mount Control

\* To disengage shift mechanism:

1. Place control lever into neutral position (**D**)
2. Press both neutral lock button (**C**) and shift disengage button (**E**).
3. Move control lever forward to increase throttle

- (**F**) Shift Mechanism Engaged  
(**G**) Shift Mechanism Disengaged

The neutral lock and shift mechanism will automatically engage when the control lever is returned to neutral position.

### Top Mount Control

\* To disengage shift mechanism:

1. Grasp the control lever hub and pull straight in for approximately 1/4 (6 mm).
2. Move control lever forward to increase throttle.

The shift mechanism will automatically engage when control lever is returned to neutral.

Your boat may be equipped with remote controls other than those described above. When not using STEYR MOTORS marine engine matched controls, ask your DEALER for operating instructions for the remote control used in your boat since operation and function may differ from STEYR MOTORS marine engine matched remote controls.

**ATTENTION:** Your boat should be equipped by manufacturer with a remote control with protection against starting in gear. Only use a remote control with start-in-neutral-only feature. This feature can prevent injury resulting from unexpected turning of the propeller and sudden movement of the boat.





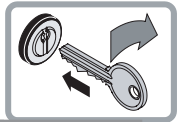

## How to Shift and Control Speed

**NOTE:** Do not shift into FORWARD or REVERSE unless engine is running. Damage to the shift mechanism could result from trying to shift without the engine running.

- 2 Move the control lever to neutral position **(D)**. The shift mechanism will automatically engage. Press neutral lock button **(C)** on some single side mount control and move the control lever to shift into forward or reverse. The throttle will begin to advance after gear engagement. Continue to move the control lever slowly in the desired direction to increase speed.

- (H)** Reverse Shift Range
- (I)** Reverse Throttle Range
- (D)** Neutral position
- (J)** Forward Throttle Range
- (K)** Forward Shift Range

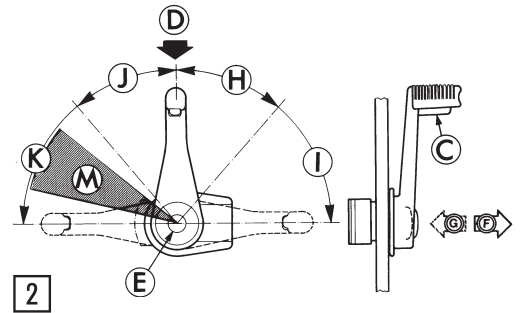

## Fuel Economy

Using the fuel economy throttle range **(M)** can save fuel depending on boat load and hull design. When the boat reaches top speed, reduce engine speed slightly. Make sure the boat maintains to plane when reducing engine speed. Continue to reduce engine speed slightly while maintaining to plane. Do not allow boat to fall off plane. This will give a comfortable ride and help to save fuel at the same time.

## Gear Box – Information

**NOTE:** You are requested to follow the instructions and recommendations provided by the marine gear box manufacturer.

## High Altitude Operation

Your **STEYR MOTORS Marine Engine** is turbocharged, and there should not be any noticeable performance loss at high altitudes.

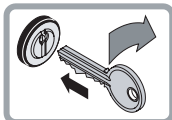

## Instrument panel

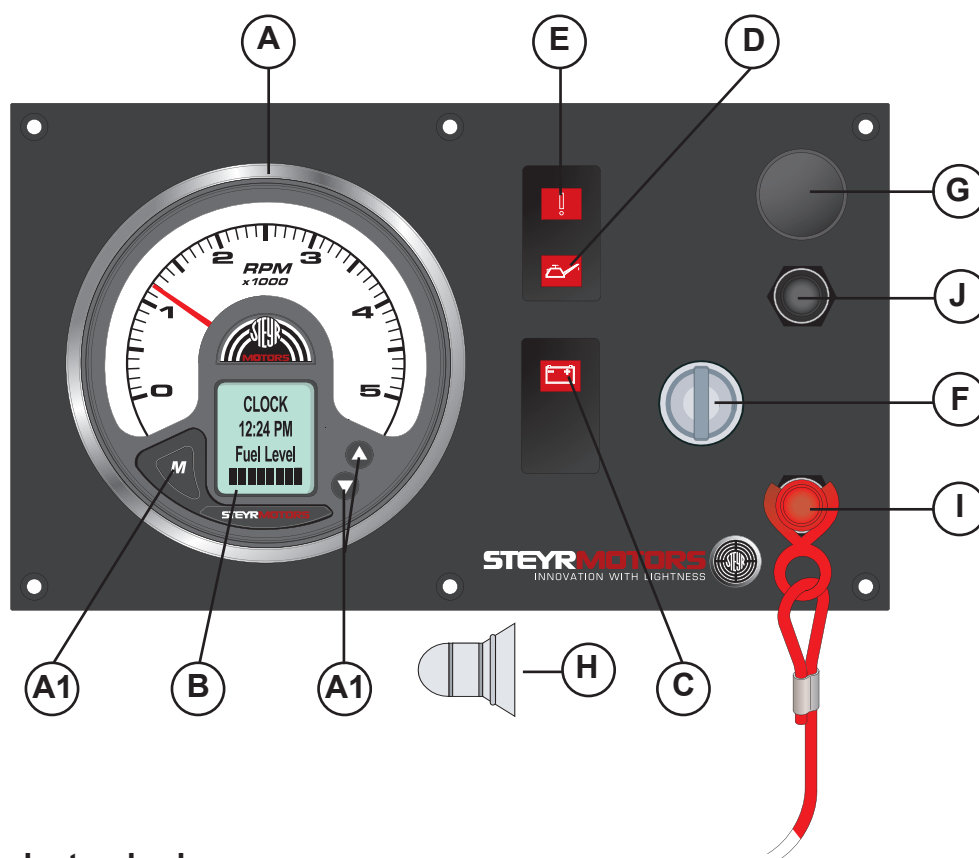

## Instrument panel, standard

- |  |  |
|--|--|
| <b>A</b> tachometer  | <b>F</b> ignition key  |
| <b>A1</b> function buttons   | <b>G</b> blind plug – installation option for key switch constant revolution |
| <b>B</b> engine parameter display  | <b>H</b> audible warning device (installed on rear side of panel)            |
| <b>C</b> warning light – battery charge  | <b>I</b> emergency cut off switch (lanyard)                                  |
| <b>D</b> combined light preheating control & warning light engine oil pressure | <b>J</b> circuit breaker (10 amp)  |
| <b>E</b> warning light check engine  |  |

If you should need additional instruments or accessories, please contact your STEYR MOTORS Marine dealer.

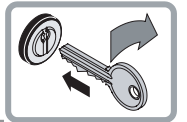

## Instrument indication during normal operation

### 1. ignition ON (... before starting)

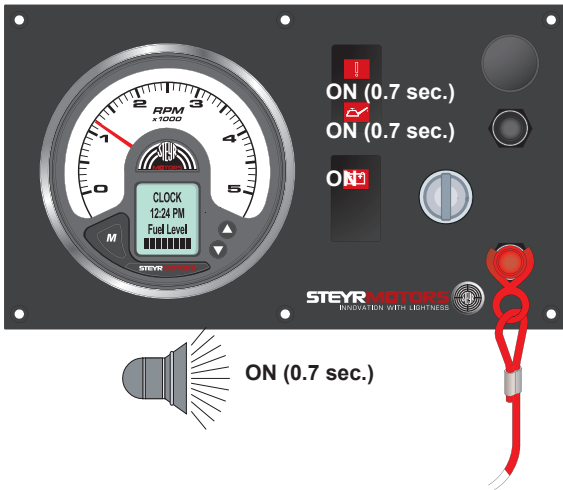

**System check** – see light indication

**NOTE:**

At low temperature condition (cold weather) the combined light for glow plug preheating & engine oil pressure will not extinguish after 0.7 sec. (glow plug preheating phase).  
In this case start engine immediately after the light extinguishes.

### 2. ignition ON (... before starting)

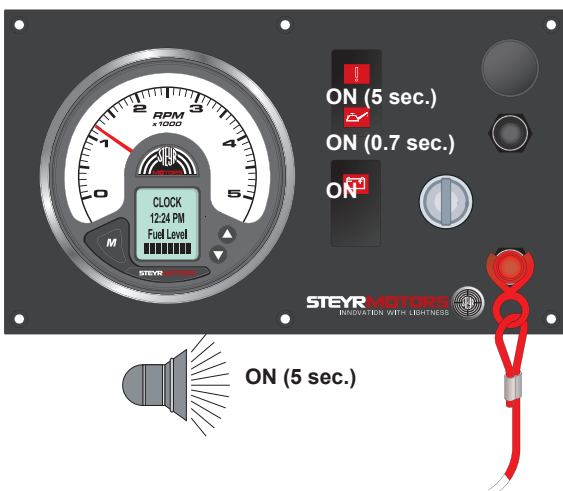

**Indication active error**

### 3. engine running (after start)

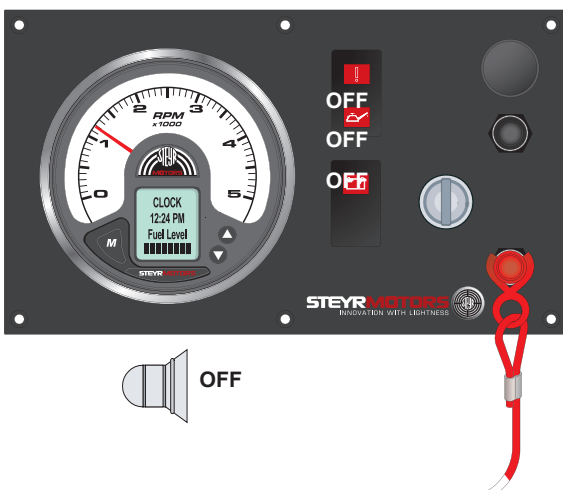

**Normal condition**

**NOTE:**

For further information see:  
“Table – Error indication on Instrument Panel”

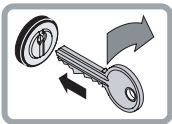

**Instrument panel (for SOLAS only)**

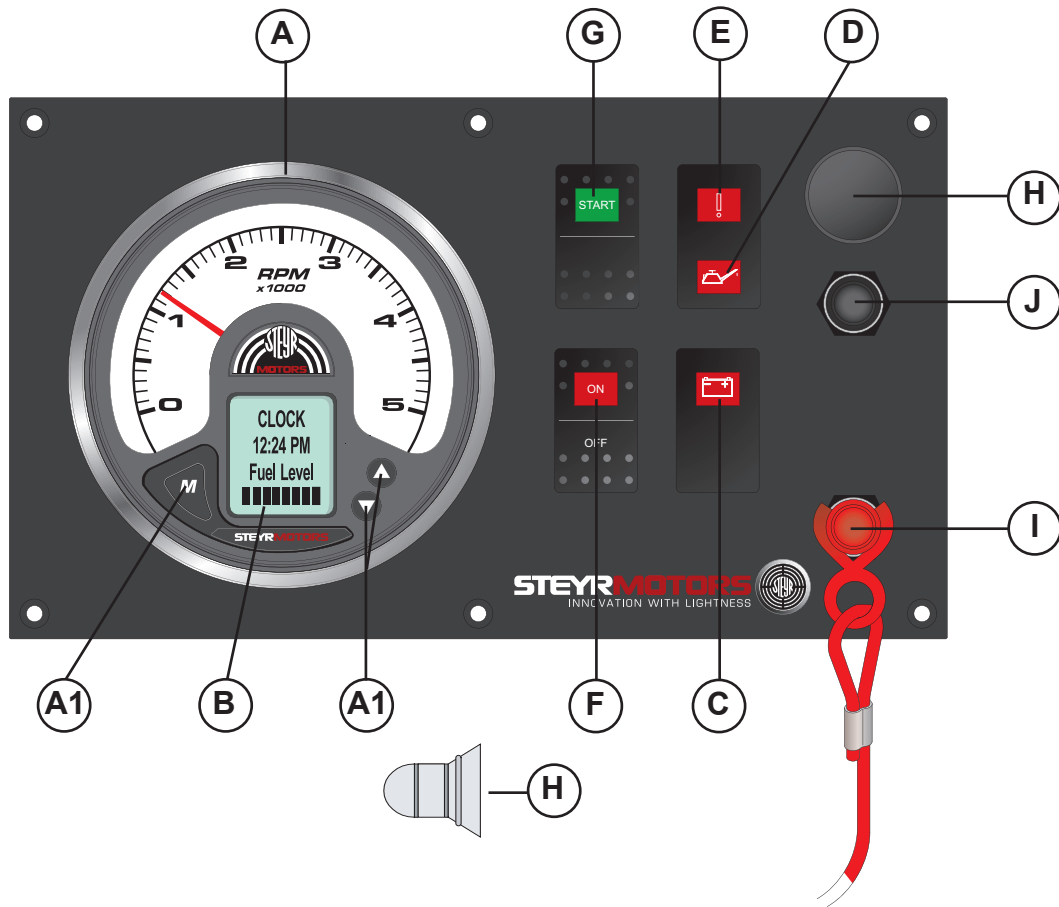

- |   |  |
|---|--|
| <b>A</b> tachometer   | <b>F</b> push button – ignition ON/OFF (red)                         |
| <b>A1</b> function buttons  | <b>G</b> push button START (green)                                   |
| <b>B</b> engine parameter display   | <b>H</b> audible warning device<br>(installed on rear side of panel) |
| <b>C</b> warning light – battery charge   | <b>I</b> emergency cut off switch (lanyard)                          |
| <b>D</b> combined light preheating control &<br>warning light engine oil pressure | <b>J</b> circuit breaker (10 amp)                                    |
| <b>E</b> warning light check engine   |  |

**NOTE:** Instrument gauges are automatically illuminated if ignition is turned ON.

**NOTE:** In the case of inversion the engine will be automatically shut off, in order to allow normal operation later.  
The ignition push button (F) must be switched OFF and ON again, then the engine can be restarted via the push button START (G).

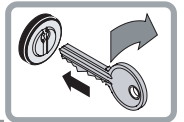

## Instrument indication during normal operation (for SOLAS only)

### 1. ignition ON (... before starting)

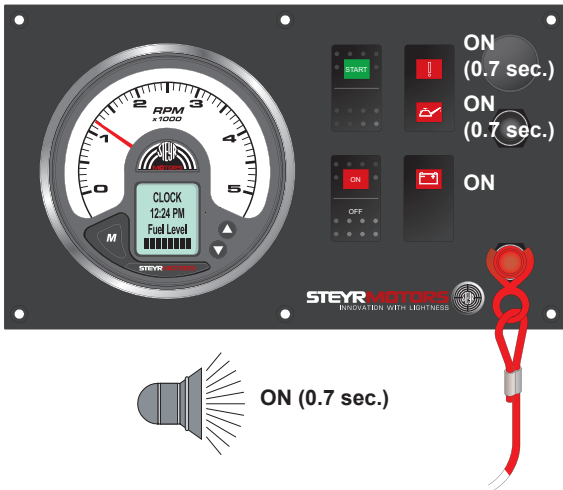

**System check** – see light indication

**NOTE:**

At low temperature condition (cold weather) the combined light for glow plug preheating & warning light engine oil pressure will not extinguish after 0.7 sec. (glow plug preheating phase). In this case start engine immediately after the light extinguishes.

### 2. ignition ON (... before starting)



**Indication active error**

### 3. engine running (after start)

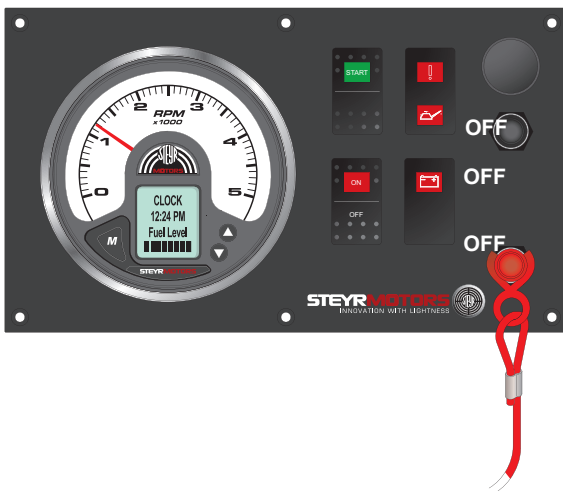

**Normal condition**

**NOTE:**

For further information see:  
“Table – Error indication on Instrument Panel”

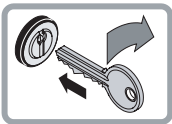

## Emergency cut off switch (Lanyard)

An emergency cut off switch is a feature on the instrument panel. Use of this switch is highly recommended. To properly use this feature, attach the lanyard securely to your clothing. Do not attach the lanyard to clothing that will tear away before the lanyard is pulled from switch to stop the engine. Using this switch is simple and should not interfere with normal operation of the boat. Care must be taken to avoid accidental pulling of lanyard during normal operation. Unexpected loss of forward motion will occur. This could allow occupants to be thrown forward. In case the emergency cut off switch had been activated (lanyard pulled) the engine can be restarted by a person if; the pull knob (ill. pos. 1) of the emergency switch is being pulled and held in this position. While holding the pull knob proceed with the normal start procedure and start engine. The engine will immediately stop if the pull knob is released under this circumstances.

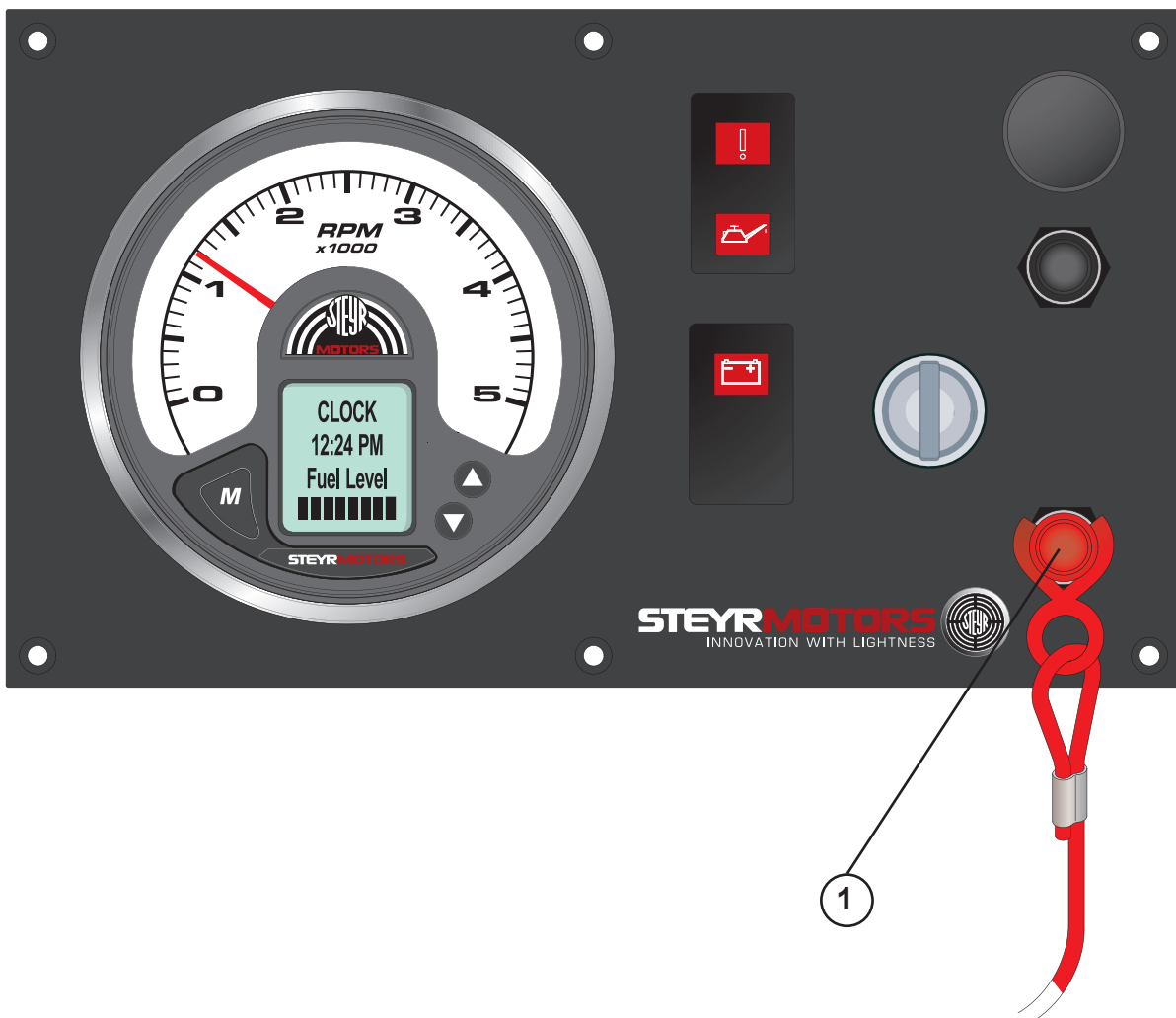

**ATTENTION:** The emergency cut off switch can only be effective when in good working condition.



Observe the following:

- \* Lanyard must always be free of entanglements that could hinder its operation.
- \* Once a month, check switch for proper operation. With engine running, pull lanyard. If engine does not stop, see your STEYR MOTORS DEALER for replacement of switch.

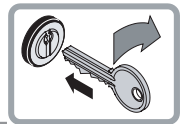

## Warning lights and audible alarm

Your boat with the **STEYR MOTORS Marine Engine** engine is equipped with three warning lights and one audible alarm (mounted behind the instrument panel) to indicate the following operation condition or system deficiencies. (The ECU will also reduce the engine power in case an important operating parameter limit has been exceeded).

- \* Indication Pre-warming Phase (combined indication through oil pressure light. Becomes affective if ambient engine coolant temperature is below 20 °C/68 °F)
- \* Break – In; over load warning
- \* Engine oil pressure too low
- \* High coolant temperature
- \* Sensors or sensor circuit defect

After ignition is turned “ON” the indication/warning lights are illuminated and the warning horn will sound for less then a second (0.7 sec.) this serves as a functional check for the optical/audible warning system.

The indication light and the warning horn remain switched on for 5 sec. after ignition “ON” if a sensor or sensor circuit defect have been detected and stored in the Engine Control Unit (ECU) (see section Instrument Panel). Please contact your nearest STEYR MOTORS Marine Dealer to get professional assistance to verify the deficiency and to correct any possible failure.

If the engine oil pressure is too low, the warning light “engine oil pressure” lights and the audible alarm sounds. The engine power will be limited. In this case proceed as follows:

- \* Check engine oil level, respectively add engine oil if necessary (refer to chapter Fuel and Lubricants)
- \* Restart engine and watch the oil pressure light. The warning light has to extinguish within 3 or 4 second after the start. If this does not happen **the engine must be stopped immediately**. (Ignition “OFF”)

In case of an overheating of the exhaust gas cooling system, the warning light “engine control” flashes and the audible alarm sounds (2 times per second); the engine power is reduced. In this case, proceed as follows:

- \* IMMEDIATELY reduce the engine to idle speed.
- \* Check an clean the raw water filter.
- \* Check the coolant temperature gauge for overheating of engine coolant. If the coolant temperature gauge indicates overheating of engine coolant, switch for a short time to REVERSE to remove a possible clogging of the raw water inlet through large plastic parts etc., and then to FORWARD. Let the engine run at idle speed for some minutes. If the temperature gauge still indicates an overheating of the engine, the engine is to be stopped. Restart the engine only after having found and eliminated the cause for alarm. See “**loss of power**” in **Trouble Shooting Chart, Technical Data and in section Maintenance**. Check coolant level and if necessary, refill coolant until an adequate coolant level is achieved. If the cause for optical/audible alarm cannot be found, consult your STEYR MOTORS Marine dealer.

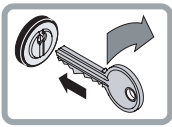

## Electronic Engine Control Unit (ECU)

The **STEYR MOTORS Marine engine** is equipped with an Electronic Engine Control Unit (ECU) that performs the following:

- \* controls engine functions to ensure maximum efficiency.
- \* self-diagnostic to protect the engine from damage if operating parameter are exceeded.
- \* stores diagnostic data of ECU server circuits for maintenance and service.
- \* stores abuse data

### Engine power is reduced if:

Operating Parameter	Effect noticed	Panel Indication	Additional Tool-Readings	Action or possible reason
High engine coolant temperature limit exceeded	Reduction of engine speed	Horn ON 2x p. sec. Gauge reading >107 °C	Steyr Diag Power limitation	See table trouble shooting: Cooling system
Defect – engine coolant sensor or sensor connection	Reduction of engine speed	Horn ON 2x p. sec. Gauge reading >120 °C	Steyr Diag Service code	Sensor or connector failure; see service code table
Exhaust temperature limit exceeded	Reduction of engine speed	Horn and indication light “CEL” ON 2x p. sec.	Steyr Diag Power limitation	See table trouble shooting: Raw water cooling system
Defect – Exhaust temperature sensor or sensor connection	Reduction of engine speed	Horn and indication light “CEL” ON 2x p. sec	Steyr Diag Service code	Sensor or connector failure; see service code table
Oil pressure below limit	Reduction of engine speed	Horn continuous and Oil indication light continuous switched ON	Steyr Diag Power limitation	See table trouble shooting: Engine oil system
Defect – Oil pressure sensor or sensor connection	Reduction of engine speed	Oil pressure indication light switched ON 1x p. sec.	Steyr Diag Service code	Sensor or connector failure; see service code table
Insufficient boost pressure or defective sensor	Reduction of engine speed		Steyr Diag Power limitation	See table trouble shooting: Air charge system
Engine speed sensor fault	Higher or unstable idle speed, limited performance	No RPM indication on tachometer	Steyr Diag Service code	See table trouble shooting: Speed sensor
Engine speed remains at idle	No increase of engine speed if throttle is moved to max.		Steyr Diag Service code	See table trouble shooting: Accelerator potentiometer failure
Governor position system	Irregular engine speed or stalled engine		Steyr Diag Service code	See table trouble shooting: Governing system



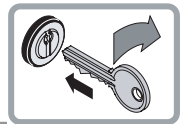

## Diagnostic system

The electronic engine control unit monitors the following engine parameters:  
oil pressure, boost pressure, coolant temperature, exhaust pipe temperature (Hi-riser), sensor control rack, potentiometer accelerator, speed signal

The ECU carries out self-diagnostic and/or plausibility checks for all input values and sensor connections. In case of irregularities, there is an optical or audible warning signal. (see page 77)

Existing active failures remain stored until the problem has been solved and the code has been cleared from the memory.

To select stored service codes, a PC with diagnostic program (VR00134/0) or diagnostic tool (VR00135/1) is necessary.

Malfunction during operation is ranked in three different categories intermittent failure, non essential failure and essential failure.

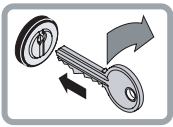

## Twin Installations

All **STEYR MOTORS Marine Engine** inboard models can also be set up for counter-rotation for twin installation. This is done by inverting direction of cable lines on shift lever in order to achieve a counter-rotation of propeller.

Counter-rotation is accomplished in the gearbox. The propeller, propeller shaft and output gear are the only parts that counter-rotate. The engine always has standard rotation.

- 4 It is customary to operate your propeller as shown on this illustration for twin installation. Some boat manufacturers may set up twin installations the opposite way. When propellers and/or cable lines are removed, care must be taken to attach them at the same position as before, and that the propellers are not exchanged.

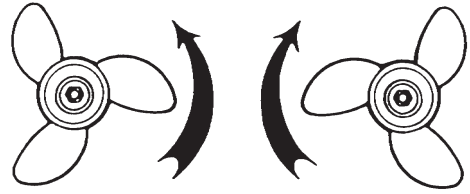

4

## Optional Propellers

- 5 Propellers are available in all regular sizes for both right- and left-hand rotation. Stainless steel has greater strength and durability than aluminium. This allows the stainless steel propeller blades to be thinner and still maintain more beam strength than aluminium propellers. The result is a more efficient propeller that gives better performance and more fuel economy.

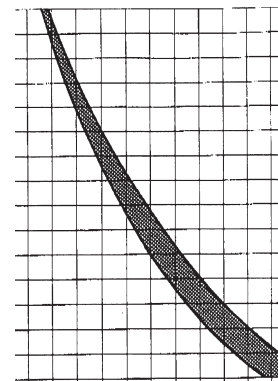

5

## Propellers

- 6 Right-hand propellers rotate clockwise to propel a boat forward. Right-hand propellers are considered standard-rotation propellers. To identify a right-hand propeller, note the angle **(A)** of the blade as seen from portside.
- 7 Left-hand propellers rotate counterclockwise to propel a boat forward. Left-hand propellers are considered counter-rotation propellers. To identify a left-hand propeller, note the angle **(B)** of the blade as seen from portside.

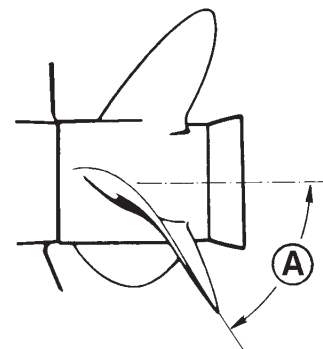

6

**NOTE:** Never interchange a right-hand propeller with a left-hand propeller. This would result in the boat being propelled in reverse when propulsion units are operated in forward gear, and forward when propulsion units are operated in reverse gear. To help you better understand and show the difference between left-hand and right-hand propellers, see illustrations.

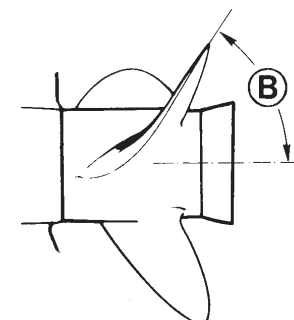

7

After having the propellers serviced, always shift into FORWARD or REVERSE at idle speed and determine whether the boat moves in the right direction. If the boat moves in the OPPOSITE direction, the propellers have not been installed properly.

**ATTENTION:** Failure to perform above test could result in loss of control.



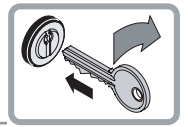

## Propeller Torque

The torque of the propeller creates forces that are transmitted to the boat. This can cause the boat to lean to one side (list).

The forces created by the counter-rotating propeller are opposite to the forces created by the standard rotating propeller. When the vertical drives are trimmed equal, these opposite forces balance each other.

## Propeller care

A damaged or unbalanced propeller will cause excessive vibration and a loss of boat speed. Under these conditions, stop the engine and check the propeller for damage. If the propeller seems to be damaged, have it checked and repaired by your local STEYR MOTORS Marine dealer. Always carry a spare propeller and replace the damaged propeller as soon as possible.

**NOTE:** Never run with a damaged propeller. Running with a damaged propeller can result in damage to drive components and engine.

## Water Jet

When using water jet drives, please contact your STEYR MOTORS Marine dealer. As to information on function and application, please refer to respective documents and documentation of the drive manufacturer.

## Operating Procedure for Freezing Temperatures

When freezing temperatures are forecast and the boat will be operated and left in the water, the propeller must remain in the tilted down (submerged) position at all times to prevent water in the vertical drive from freezing. Upon completion of engine operation, drain the engine as described in **Off-Season Storage Preparations**.

## Salt Water Operation

Fresh water to flush the raw water circuit is recommended after use in salt, polluted, or brackish water to prevent deposits from clogging and corroding the cooling passages. Contact your STEYR MOTORS Marine dealer to obtain an Engine Flushing Kit that allows flushing of the engine when in or out of the water.

**NOTE:** Use in salt or brackish water may require additional anti-corrosion protection.

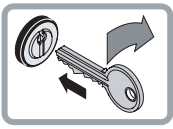

## Fuel Pump

The **STEYR MOTORS Marine Engine** is equipped with an electric fuel pump. It is turned “ON” and “OFF” with the key switch. If the engine is not started within 10 seconds after turning the key switch “ON”, the fuel pump is automatically turned off.

## Fuel System Checks

Fill the tank with the recommended fuel. Keeping tanks full reduces water condensation and helps keep fuel cool, which is important to engine performance.

Make sure that fuel supply valves (if used) are open, and valve cock seals are absolutely (gas) tight.

To insure a prompt start and an even run of the engine, the fuel system is to be rinsed by means of the electric fuel pump (ignition “ON” several times for app. 10 sec.) before starting the engine the first time and/or after every replacement of a fuel filter.

Refill at the end of each day’s operation to prevent condensation from contaminating the fuel. Condensation formed in a partially filled tank promotes the growth of microbial organisms that can clog fuel filters and restrict fuel flow.

If the engine is equipped with a fuel/water separator, drain off any water that has accumulated. Water in fuel can seriously affect engine performance and may cause engine damage. **STEYR MOTORS recommends to install a fuel/water filter with a flow rate of at least 300 l/h at a pressure difference of <200 mbar.**

## Fuel Contamination

In the marine environment, the most likely fuel contaminants are water and microbial growth (black “slime”). Generally, this type of contamination is the result of poor fuel handling practices. Black “slime” requires water in the fuel to form and grow; the best prevention is to keep water content in storage tank to a minimum.

Treating fuel with microbial growth requires the use of fuel additive.

**STEYR MOTORS** does recommend the use of fuel additives such as Biobor JF, or equivalent, for treatment of microbiological fuel contamination. Follow the manufacturers instructions for use. If treating fuel, frequent fuel filter changes will be necessary until fuel system is purged.

**NOTE:** A galvanized steel tank should never be used for fuel storage, because the fuel reacts chemically with the zinc coating forming powdery flakes which can quickly clog the fuel filters and damage the fuel pump and injectors.

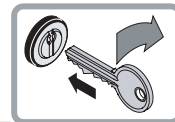

## Cooling System (Function Description)

STEYR MOTORS Marine Engines are equipped with a closed (internal) and an open (external cooling circuit).

### 8 Closed Cooling Circuit

The closed cooling circuit includes monoblock as well as exhaust manifold, heat exchanger and expansion tank. Temperature in the closed cooling circuit is precisely controlled by means of thermostat. The thermostat determines the amount of coolant circulating through the heat exchanger, thus controlling the operating temperature of the engine.

A temperature sensor (8/A) controls the cooling temperature. An excessive temperature rise of the coolant will cause an optical and audible alarm (see chart "Error indication on Panel Section"). In this case, engine power will be reduced.

The temperature gauge on the instrument panel indicates the coolant temperature of the engine.

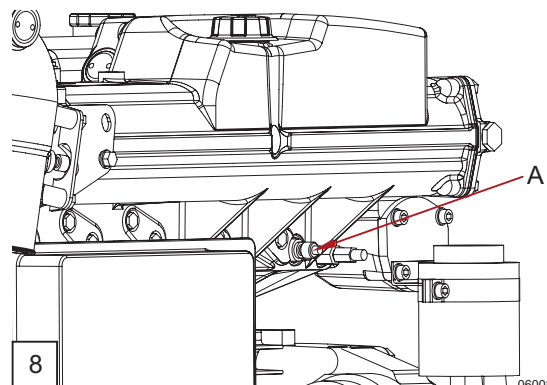

### 9 Open Cooling Circuit (Raw Water Circuit)

Thermal energy transferred by the engine and absorbed by the engine coolant is drained via the (external) raw water circuit. Raw water is sucked by the pump via the raw water intake, constantly pumped through supercharger intercooler and heat exchanger, and discharged together with the exhaust gas via the sprinkler. During discharging, the raw water entering the exhaust pipe additionally cools the exhaust gas.

A temperature sensor (9/A) monitors the raw water- and exhaust gas temperature. An excessive rise will cause an optical and audible alarm (see chart "Error indication on Panel Section"). In this case, the engine power will be reduced too.

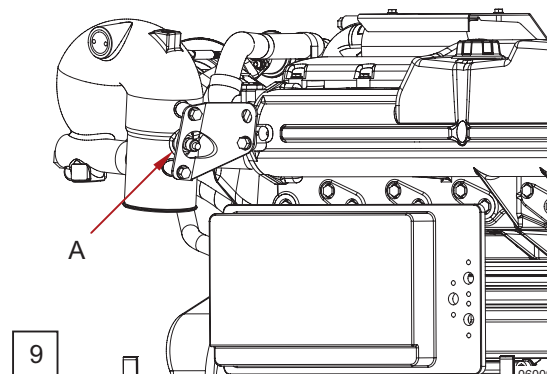

**NOTE:** Should engine overheat at high speeds, slowly reduce RPM to idling to prevent damages to the engine. In case of overheating problems, contact your STEYR MOTORS Marine dealer.

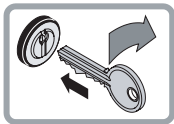

## Electrical Equipment

The electrical equipment of your **STEYR MOTORS Marine engine** primarily consists of an alternator with transistorized voltage regulator, battery and all necessary connecting cables and leads.

### Alternator

The alternator is driven via a **poly-V-belt** resp. serpentine belt from the **4 cyl.** engines and via a V-belt from the **6 cyl.** engines and charges the battery at all engine speeds. Output at idle speed is ~ 30 A/12 V and will rise with an engine speed of 3,000 rpm to maximum output of 90 A/12 V.

#### Optional:

The 6 cylinder marine engines may be equipped with an optional 80 A/24 V alternator and DC/DC charger system kit.

### Battery

#### FOR ALL 4 CYL. MARINE ENGINES

Use a 12-volt battery with a cold testing circuit of 450 A at  $-18^{\circ}\text{C}$  and a **capacity of 92 Ah** at  $27^{\circ}\text{C}$ , to ensure the supply of the electric and electronic components at all operating conditions.

#### FOR ALL 6 CYL. MARINE ENGINES

Use a 12-volt battery with a cold testing circuit of 650 A at  $-18^{\circ}\text{C}$  and a **capacity of 115 Ah** at  $27^{\circ}\text{C}$ , to ensure the supply of all electric and electronic components.

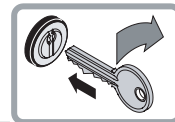

**ATTENTION:** \* Do not use jumper cables and a booster battery to start engine. Remove battery from boat and recharge.



– WRONG CONNECTION WILL DESTROY ELECTRONIC SYSTEM –

\* Do not charge battery in boat. Fumes vented during battery charging can lead to an explosion.

\* **Battery electrolyte is a corrosive acid and should be handled with care.**

If electrolyte is spilled or splashed on any part of the body, immediately flush the exposed area with liberal amounts of water and obtain medical aid as soon as possible.

High resistance in the charging circuit can seriously affect the operation of the electrical system. Unless there is definite malfunction in the electrical system, high resistance is sometimes caused by corroded or loose connections. Wherever practical, the electrical connections on your engine have been sealed. However, we recommend that you make periodic inspections to ensure clean, tight connections throughout the electrical system.

**NOTE:** It is important that the battery connections are correct. The negative battery cable must be attached to the negative terminal (–) on the battery and the engine's positive cable must be attached to the positive terminal (+) on the battery. **If these connections are reversed, the regulating unit may be immediately damaged.**

Inspect your battery at regular intervals for specific gravity (state of charge), individual cell water level, cleanliness and clean, tight connections.

If the battery has become discharged for no apparent reason, check all electrical system components for malfunction, or a switch left in ON position prior to installing recharged battery.

## Circuit Breakers

**STEYR MOTORS Marine Engine** models are protected against overload by circuit breakers.

**10** On the base plate of the E-box three thermal triggered 50 amp. circuit breakers are installed. **(F2)** protects the electric circuit of the glow plugs of cylinder 1 & 2 (4 cyl.) and 1 – 3 (6 cyl.); **(F3)** protects the electric circuit for the glow plugs of cylinder 3 & 4 (4 cyl.) and 4 – 6 (6 cyl.); **(F1)** protects electric system and electronic management. The ignition key and instruments are protected by a 10 amp. Fuse located in the main wiring harness **under the instrument panel** (at height of ignition key).

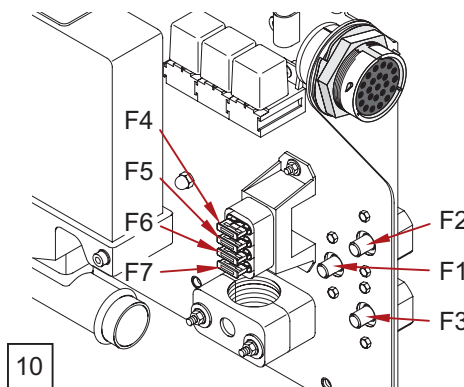

- F4** Fuse supply module
- F5** Fuse main circuit supply
- F6** Fuse fuel-pump circuit
- F7** Fuse glow-plug circuit
- F9** Fuse ignition switch circuit (instrument panel)

The installation of any additional electrical accessories requires the protection of individual circuits. Consumption of current should occur directly at the battery.

**NOTE:** Avoid sparks that will damage the alternator or ECU. Do not attempt to connect or disconnect any part of the electrical system while the engine is running. Fuses for fuel, ECU-supply, glow plug-relay are inside the E-box cover.

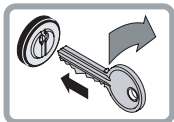

## Inversion Switch

- 11** The inversion switch is a mercury switch **(A)** which is actuated in case of an inclination of the boat in any direction over 70°.

Via the main circuit relay the engine is shut down. **For safe guarding reasons the inversion switch is to be checked every 50 hrs or 6 months.** (See service- and maintenance chart page 64).

**ATTENTION:** After such an event, this temporarily stored operating condition is to be cancelled from the engine management system by ignition "OFF" = "Reset". Without "Reset", a new start of the engine is not possible.

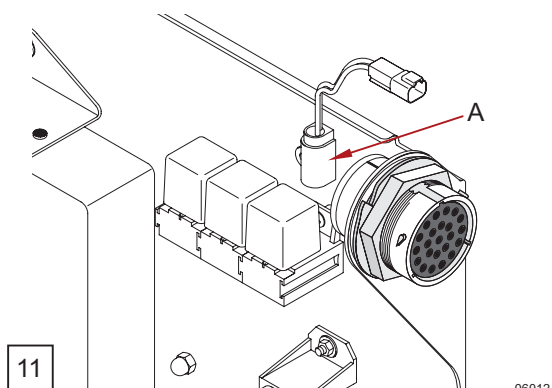

## Interrupt crankshaft housing ventilation

- 12** During an activation of the mercury switch inversion, the bypass valve **(B)** for crankshaft housing ventilation is closed too. This avoids a possible oil outlet via suction through the air filter.

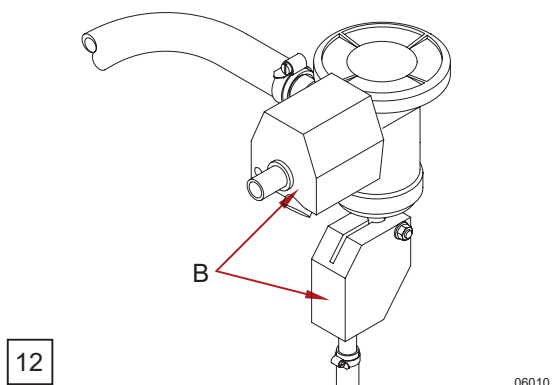

## Instrument Panel

The engines are supplied with the standard instrument panel. The respective customer may use a self-adapted STEYR MOTORS instrument panel or one which corresponds to his own ideas and requirements.

**ATTENTION:** For not approved alterations which lead to engine failure, no liability can be undertaken.



## Dry Operation

After a dry operation of the engine (without raw water cooling), check the impeller of the raw water pump for damages. Replace if necessary. Grease the impeller, use grease from special impeller kit Z011753/2.





## FUEL AND LUBRICANTS

Fuel Requirements .....	42
How to Select Fuel .....	42
Fuel Selection Chart .....	42
Engine Lubrication .....	43
Motor Oil .....	43
Oil Identification Symbol .....	43
Disposal of Automotive Waste Products .....	44



## Fuel Requirements

The **STEYR MOTORS Marine Engines** are designed for maximum fuel economy. To maintain optimum performance, use diesel fuel according to CEC RF-03-A-84 or equivalent to meet this specification. When temperatures are below  $-7\text{ }^{\circ}\text{C}$  ( $20\text{ }^{\circ}\text{F}$ ), use diesel fuels with additives for low temperature operation.

## How to Select Fuel

Fuel quality is an important factor in obtaining satisfactory engine performance, long engine life, and acceptable exhaust emission levels. Direct injected diesel engines are designed to operate with most diesel fuels marketed today. In general, fuels meeting the properties of CEC RF-03-A-84 have provided satisfactory performance. The ASTM D 975 specification, however, does not adequately define the fuel characteristics needed to guarantee the fuel quality. The properties listed in the following fuel selection chart have provided optimum engine performance.

## Fuel Selection Chart

General Fuel classification	CEC RF-03-A-84 Limit value and units	CEC RF-03-A-80 Limit value and units	ASTM – Test procedure
Cetane number	min. 49 – max. 53	min. 51 – max. 57	D 613 (D 976)
Gravity at 15 °C (kg/l)	min. 0.835 max. 0.845	min. 0.835 max. 0.845	D 1298
Distillation			
50 %	min. 245 °C	min. 245 °C	D 86
90 %	min. 320 °C max. 340 °C	min. 320 °C max. 340 °C	
End point	max. 370 °C	max. 370 °C	
Flash point	min. 55 °C	min. 55 °C	D 93
CFPP (Cloud point)	max. $-5\text{ }^{\circ}\text{C}$	max. $-5\text{ }^{\circ}\text{C}$	EN 116 (CEN)
Viscosity Kinematic 40 °C	min. 2.5 mm <sup>2</sup> /s max. 3.5 mm <sup>2</sup> /s	min. 2.5 mm <sup>2</sup> /s max. 3.5 mm <sup>2</sup> /s	D 445
Sulfur content	min. 0.2 mass-% max. 0.3 mass-%	min. 0.2 mass-% max. 0.5 mass-%	D 1266/D 2622 D 2785
Copper corrosion	max. 1	max. 1	D 130
Carbon residue Conradson number (10 % settling)	max. 0.2 mass-%	max. 0.2 mass-%	D 189
Ash	max. 0.01 mass-%	max. 0.01 mass-%	D 482
Water content	max. 0.05 mass-%	max. 0.05 mass-%	D 95/D 1744
Acid content (strong acid)	max. 0.20 mg KOH/g	max. 0.20 mg KOH/g	D 974
Oxidation stability	max. 2.5 mg/100 ml	max. 2.5 mg/100 ml	D 2274



## Engine Lubrication

If you choose to lubricate your **STEYR MOTORS Marine Engine** yourself, refer to the **Lubrication and Inspection Chart** for lubrication points and recommended lubricants. Use only STEYR MOTORS recommended lubricants or lubricants of equivalent quality and viscosity. See your STEYR MOTORS dealer for recommended lubricants.

If you choose to have your **STEYR MOTORS Marine Engine** lubricated, see your local dealer. He will gladly lubricate it at the required intervals.

## Motor Oil

To obtain the best engine performance and engine life, **STEYR MOTORS TURBO Diesel Engine Oil SAE 5 W-50 or 10 W-40 (Z010058/0)** is recommended. Motor oils are specified by **ACEA**, **API** service codes and **SAE** viscosity numbers. If **STEYR MOTORS TURBO Diesel Engine Oil** is not available, you are required to use a reputable brand of motor oil labelled for **ACEA E7 or B4-02**, **API CF** Service codes and **SAE** viscosity number **5 W-50** or **10 W-40**. Refer to oil identification symbol on the container.

Initial factory fill is a full synthetic high quality break-in oil specified **ACEA E7, API CF, SAE 10 W-40**. During the break-in period (initial 20 hours), frequently check the oil level. Somewhat higher oil consumption is normal until piston rings are seated. The oil level should be maintained between the minimum and maximum marks on the dipstick. The space between the marks represents approximately 3.7 quarts (3.5 litres). For **oil level dipstick location**, refer to section **Maintenance**.

After first 50 hours of operation change the motor oil and replace the oil filter. Refer to Service and Maintenance Schedule.

## Oil Identification Symbol

Motor oils are specified by **ACEA**, **API** service codes, and **SAE** viscosity numbers. These may be found on the label, top of can, or oil identification symbol.

**NOTE:** Some oils meet more than one **ACEA** or **API** service rating. The recommended **ACEA** or **API** service codes must be among these service ratings.

**13** Top of Can

**14** Oil Identification Symbol



ACEA E7 or B4-02  
API CF

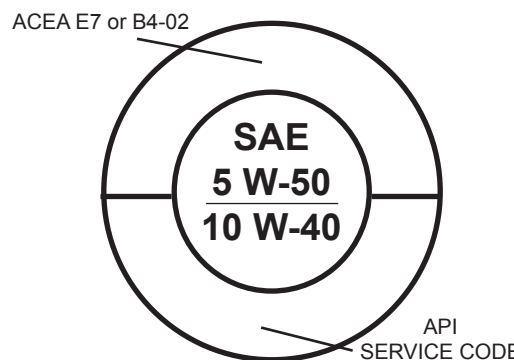



## Disposal of Automotive Waste Products

Used fuel and oil is to be collected in separate containers to permit an eventual subsequent treatment.



**The disposal of any fuel and oil for the engine is subject to the special waste act. The “special waste catalogue” önorm s2100 refers to the necessary disposal in Austria. Please follow the local regulations of your country.**

The operating and maintenance personnel has to take care that fuel and oil as well as other material ranking as special waste are deposited at the respective collecting points.

Code No.	Designation
31 423	oil contaminated ground or oil binder
54 102	waste oil
54 104	fuel
54 202	grease
54 207	vaseline
54 917	compact sealing material
54 927	oil contaminated scouring cloth
54 928	used oil- and air filters
55 510	colour- or varnish containing waste

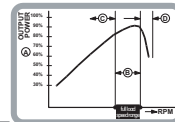

## TECHNICAL DATA

Model and Serial Numbers .....	47
Technical Data and Overview	
MO54NA33 .....	48
Technical Data and Overview	
MO84K32, MO94K33, MO114K33 .....	50
Technical Data and Overview	
MO144M38, MO164M40, MO174V40 .....	52
Technical Data and Overview	
MO196K35, MO236K42 .....	54
Technical Data and Overview	
MO256K43, MO256H45 .....	56
Technical Data and overview	
MO286H43, MO126K25, MO156K25 .....	58
Technical data and overview	
MO306H43WJ .....	60

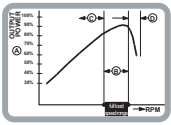

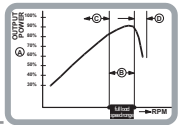

## Model and Serial Numbers

The model and serial number (see ill. 15/16) is located on the engine as illustrated.

**These numbers are required for warranty claims and ordering parts.**

### FOR ALL 4 CYL. MARINE ENGINES

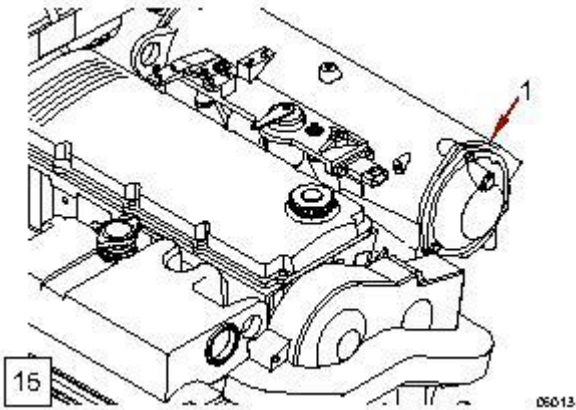

### FOR ALL 6 CYL. MARINE ENGINES

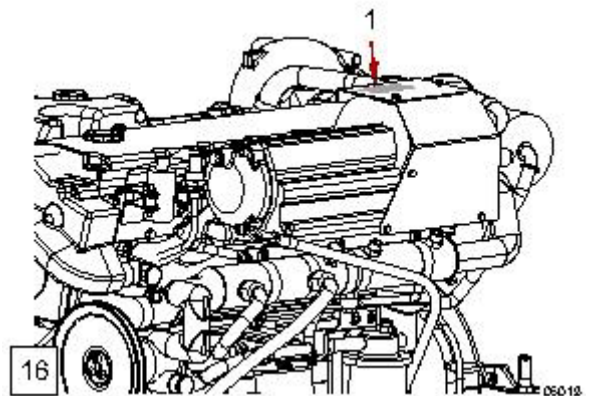

- 17** The model and serial number of the marine gearbox is located on the marine gearbox housing as illustrated.

To obtain instructions regarding marine gearbox operation, refer to marine gearbox owners manual.

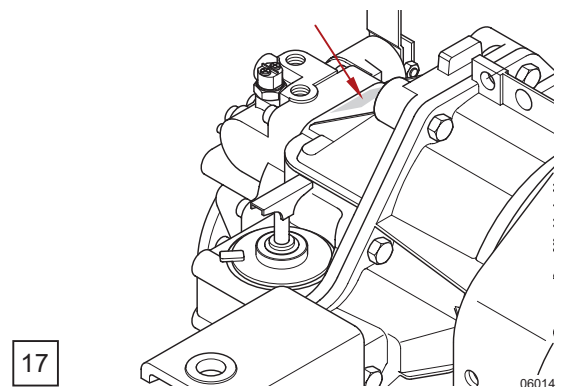

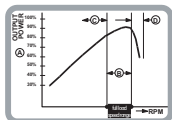

**Technical Data and Overview MO54NA33**

MAKE	STEYR MOTORS M 14 TCM, TCAM
type	MO54NA33
displacement	2,133 cm <sup>3</sup>
piston displacement	85.0 x 94.0 mm
rated power acc. EN ISO 8665:2006 (impeller*) KW/HP Jet – Drive/Inboard Z – Drive	39/52 38/52
number of cylinders	4-cylinder in-line engine (position of cyl. 1 at vibration damper side)
ignition order	1 – 3 – 4 – 2
sense of rotation, seen from front	right
compression ratio	17.0:1
full-load speed range (rpm)	3,300 rpm (+0 rpm/–200 rpm)
idle speed	700 rpm (adjustable)
injection	Plunger activated, two stage, high pressure with electronically controlled injection rate
fuel	acc. to CEC RF-03-A-84 (DIN 51601) Cetan >45; diesel fuel No. 2-D, temperature above –7 °C; No.1-D, temperature below –7 °C
fuel filter	refer to spare part catalogue
fuel filter location	intake-sided
air filter	refer to spare part catalogue
oil pressure above 2,000 rpm	400 – 700 kPa (58 – 101 PSI) microprocessor controlled
filling capacity motor oil	approx. 8.0 l engine housing (incl. approx. 1 l oil filter contents)
specification motor oil	SAE 5W-50/ACEA B4-02/API CF or 10W-40/ACEA E4, E5, E7/API CF P/N0. Z010058/0
oil and oil filter change intervals**)	every 150 operating hours and/or once per season
oil filter	refer to spare part catalogue
oil filter location	pressure-sided
electric charging system	14 V/90 A alternator with transistorized voltage regulator
cooling system	dual cooling circuit; thermostat-controlled, pressurized cooling circuit; circulating pump with heat exchanger on engine; governor pump, external raw water circuit to heat exchange
coolant capacity	11.5 liters
coolant	STEYR MOTORS engine coolant –36 °C P/No. Z011785/0

\*) Efficiency of gearbox = 97.0 %, efficiency of Z-Drive = 95.5 %

\*\*\*) Extended periods to be evaluated upon application and type of usage STEYR MOTORS GmbH.  
Reserves the right to make changes without notice or obligations.



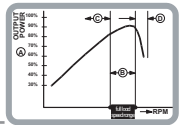

**Overview for all STEYR MOTORS 4 Cyl. Marine Engines**

Item	Designation
1	Zinc Anode (2 Units)
2	Model and Serial Number
3	Intake Manifold
5	Fuel Pump
6	Oil Seperator
7	Raw Water Drain Plug
8	Valve Crankshaft Housing Ventilation (only SOLAS)
9	Oil Drain Plug
10	Fuel Filter1
11	Oil Filter
12	Hydraulic Pump
13	Raw Water Inlet Fitting
14	Raw Water Pump
15	Coolant Drain Plug (2 Units)
16	Engine Oilcooler
17	Oil Suction Pipe
18	Oil Dipstick
19	Hydraulic Oil Tank
20	Cooler Cap
21	Potentiometer Accelerator
22	Motor Oil Filler Cap
24	Rack Position Sensor*)
25	Drive Belt
26	Cover T-Belt, Lower
27	Engine Mount
28	Drive Belt Tensioner
29	Vibration Damper
30	Cover T-Belt, Upper
31	Engine Lifting Eye
32	Speed Sensor
33	Valve Cover
34	Heat Exchanger
35	Coolant Expansion Tank
36	Diagnostic Outlet
37	Inversion Switch (only for SOLAS)
38	Connector Instrument Panel
39	Coolant Temperature Sensor
40	Thermostat Housing
41	Alternator
42	Circuit Breakers
43	Engine Management System/Fuses
44	Exhaust Temperature Sensor
45	Air Filter
47	Exhaust Elbow
48	Starter Relais (Backside E-Box Ground Plate)
49	Starter Motor
50	Flywheel
51	Flywheel Housing
52	Oil Pressure Sensor

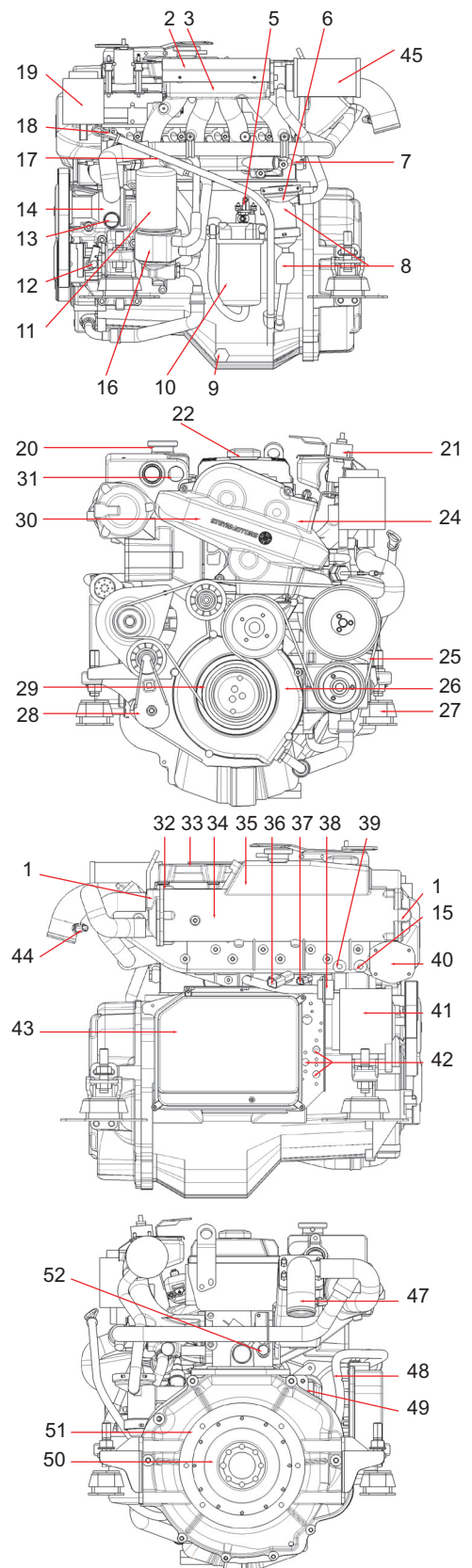

\*) This sensor is magnetism sensitive. All external magnets must be kept away.

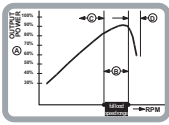

MO84K32  
MO94K33  
MO114K33

## Technical Data and Overview MO84K32, MO94K33, MO114K33

MAKE	STEYR MOTORS M 14 TCM, TCAM		
type	MO84K32	MO94K33	MO114K33
displacement	2,133 cm <sup>3</sup>		
piston displacement	85.0 x 94.0 mm		
rated power acc. EN ISO 8665:2006 (impeller*) KW/HP Jet – Drive/Inboard Z – Drive	53/71 52/70	64/86 63/84	78/105 77/104
number of cylinders	4-cylinder in-line engine (position of cyl. 1 at vibration damper side)		
ignition order	1 – 3 – 4 – 2		
sense of rotation, seen from front	right		
compression ratio	17.5:1		
full-load speed range (rpm)	3,200 rpm (+0 rpm/–200 rpm)	3,300 rpm (+0 rpm/–200 rpm)	3,800 rpm (+0 rpm/–200 rpm)
idle speed	700 rpm (adjustable)		
injection	Plunger activated, two stage, high pressure with electronically controlled injection rate		
fuel	acc. to CEC RF-03-A-84 (DIN EN 590) Cetan >49; diesel fuel No. 2-D, temperature above –7 °C; No.1-D, temperature below –7 °C		
fuel filter	refer to spare part catalogue		
fuel filter location	intake-sided		
air filter	refer to spare part catalogue		
oil pressure above 2,000 rpm	400 – 700 kPa (58 – 101 PSI) microprocessor controlled		
filling capacity motor oil	approx. 8.0 l engine housing (incl. approx. 1 l oil filter contents)		
specification motor oil	SAE 5W-50/ACEA B4-02/API CF or 10W-40/ACEA E4, E5, E7/API CF P/N0. Z010058/0		
oil and oil filter change intervals**)	every 150 operating hours and/or once per season		
oil filter	refer to spare part catalogue		
oil filter location	pressure-sided		
electric charging system	14 V/90 A alternator with transistorized voltage regulator		
cooling system	dual cooling circuit; thermostat-controlled, pressurized cooling circuit; circulating pump with heat exchanger on engine; governor pump, external raw water circuit to heat exchange		
coolant capacity	11.5 liters		
coolant	STEYR MOTORS engine coolant –36 °C P/No. Z011785/0		

\*) Efficiency of gearbox = 97.0 %, efficiency of Z-Drive = 95.5 %

\*\*\*) Extended periods to be evaluated upon application and type of usage STEYR MOTORS GmbH.  
Reserves the right to make changes without notice or obligations.

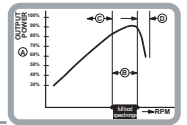

## Overview for all STEYR MOTORS 4 Cyl. Marine Engines

Item	Designation
1	Zinc Anode (4 Units)
2	Model and Serial Number
3	Intercooler
4	Fuel/Oil Cooler with Raw Water Drain Plug
5	Fuel Pump
6	Oil Seperator
7	Raw Water Drain Plug
8	Valve Crankshaft Housing Ventilation (only SOLAS)
9	Oil Drain Plug
10	Fuel Filter
11	Oil Filter
12	Hydraulic Pump
13	Raw Water Inlet Fitting
14	Raw Water Pump
15	Coolant Drain Plug (2 Units)
16	Engine Oilcooler
17	Oil Suction Pipe
18	Oil Dipstick
19	Hydraulic Oil Tank
20	Cooler Cap
21	Potentiometer Accelerator
22	Motor Oil Filler Cap
23	Boost Pressure Sensor
24	Rack Position Sensor*)
25	Drive Belt
26	Cover T-Belt, Lower
27	Engine Mount
28	Drive Belt Tensioner
29	Vibration Damper
30	Cover T-Belt, Upper
31	Engine Lifting Eye
32	Speed Sensor
33	Valve Cover
34	Heat Exchanger
35	Coolant Expansion Tank
36	Diagnostic Outlet
37	Inversion Switch (only for SOLAS)
38	Connector Instrument Panel
39	Coolant Temperature Sensor
40	Thermostat Housing
41	Alternator
42	Circuit Breakers
43	Engine Management System/Fuses
44	Exhaust Temperature Sensor
45	Air Filter
46	Turbo Charger
47	Exhaust Elbow
48	Starter Relais (Backside E-Box Ground Plate)
49	Starter Motor
50	Flywheel
51	Flywheel Housing
52	Oil Pressure Sensor

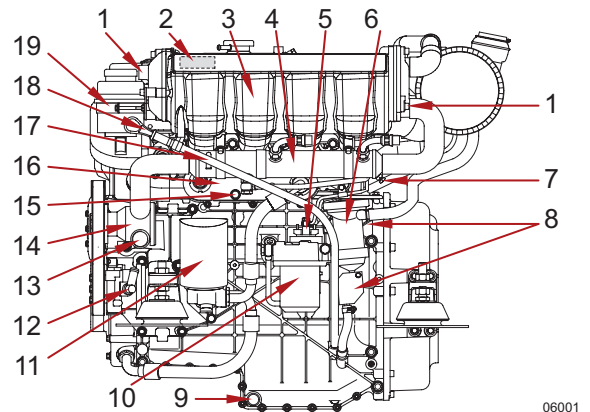

06001

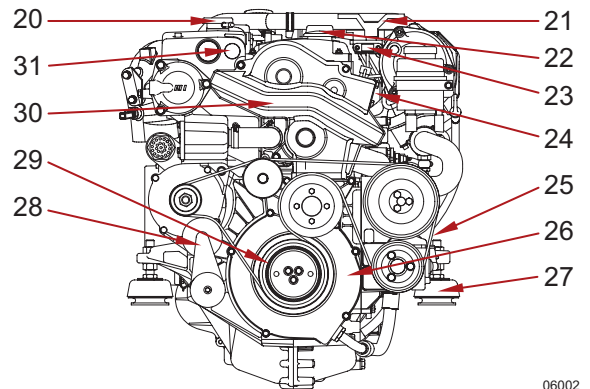

06002

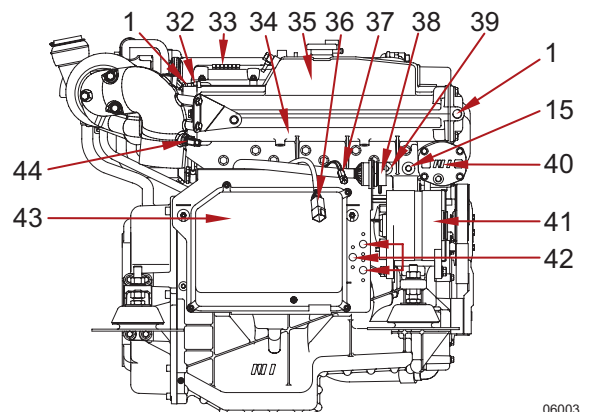

06003

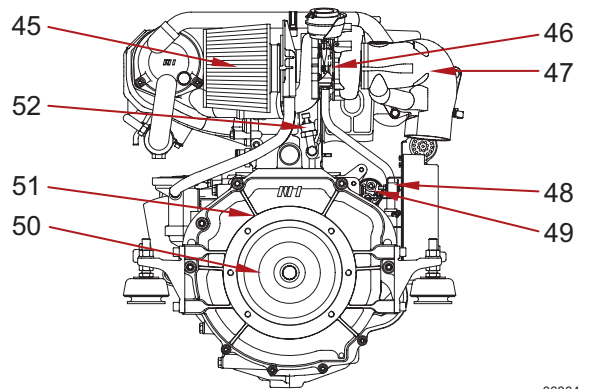

06004

\*) This sensor is magnetism sensitive. All external magnets must be kept away.

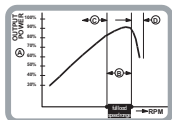

MO144M38  
MO164M40  
MO174V40

## Technical Data and Overview MO144M38, MO164M40, MO174V40

MAKE	STEYR MOTORS M 14 TCM, TCAM		
type	MO144M38	MO164M40	MO174V40
displacement	2,133 cm <sup>3</sup>		
piston displacement	85.0 x 94.0 mm		
rated power acc. EN ISO 8665:2006 (impeller*) KW/HP Jet – Drive/Inboard Z – Drive	103/138 101/136	116/156 114/154	121/165 119/162
number of cylinders	4-cylinder in-line engine (position of cyl. 1 at vibration damper side)		
ignition order	1 – 3 – 4 – 2		
sense of rotation, seen from front	right		
compression ratio	17.5:1		17.0:1
full-load speed range (rpm)	3,800 rpm (+0 rpm/–300 rpm)	4,000 rpm (+0 rpm/–300 rpm)	4,000 rpm (+0 rpm/–300 rpm)
idle speed	700 rpm (adjustable)		
injection	Plunger activated, two stage, high pressure with electronically controlled injection rate		
fuel	acc. to CEC RF-03-A-84 (DIN EN 590) Cetan >49; diesel fuel No. 2-D, temperature above –7 °C; No.1-D, temperature below –7 °C		
fuel filter	refer to spare part catalogue		
fuel filter location	intake-sided		
air filter	refer to spare part catalogue		
oil pressure above 2,000 rpm	400 – 700 kPa (58 – 101 PSI) microprocessor controlled		
filling capacity motor oil	approx. 8.0 l engine housing (incl. approx. 1 l oil filter contents)		
specification motor oil	SAE 5W-50/ACEA B4-02/API CF or 10W-40/ACEA E4, E5, E7/API CF P/NO. Z010058/0		
oil and oil filter change intervals**)	every 150 operating hours and/or once per season		
oil filter	refer to spare part catalogue		
oil filter location	pressure-sided		
electric charging system	14 V/90 A alternator with transistorized voltage regulator		
cooling system	dual cooling circuit; thermostat-controlled, pressurized cooling circuit; circulating pump with heat exchanger on engine; governor pump, external raw water circuit to heat exchange		
coolant capacity	11.5 liters		
coolant	STEYR MOTORS engine coolant –36 °C P/No. Z011785/0		

\*) Efficiency of gearbox = 97.0 %, efficiency of Z-Drive = 95.5 %

\*\*\*) Extended periods to be evaluated upon application and type of usage STEYR MOTORS GmbH.  
Reserves the right to make changes without notice or obligations.

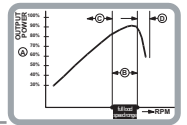

**Overview for all STEYR MOTORS 4 Cyl. Marine Engines**

Item	Designation
1	Zinc Anode (4 Units)
2	Model and Serial Number
3	Intercooler
4	Fuel/Oil Cooler with Raw Water Drain Plug
5	Fuel Pump
6	Oil Seperator
7	Raw Water Drain Plug
8	Valve Crankshaft Housing Ventilation (only SOLAS)
9	Oil Drain Plug
10	Fuel Filter
11	Oil Filter
12	Hydraulic Pump
13	Raw Water Inlet Fitting
14	Raw Water Pump
15	Coolant Drain Plug (2 Units)
16	Engine Oilcooler
17	Oil Suction Pipe
18	Oil Dipstick
19	Hydraulic Oil Tank
20	Cooler Cap
21	Potentiometer Accelerator
22	Motor Oil Filler Cap
23	Boost Pressure Sensor
24	Rack Position Sensor*)
25	Drive Belt
26	Cover T-Belt, Lower
27	Engine Mount
28	Drive Belt Tensioner
29	Vibration Damper
30	Cover T-Belt, Upper
31	Engine Lifting Eye
32	Speed Sensor
33	Valve Cover
34	Heat Exchanger
35	Coolant Expansion Tank
36	Diagnostic Outlet
37	Inversion Switch (only for SOLAS)
38	Connector Instrument Panel
39	Coolant Temperature Sensor
40	Thermostat Housing
41	Alternator
42	Circuit Breakers
43	Engine Management System/Fuses
44	Exhaust Temperature Sensor
45	Air Filter
46	Turbo Charger
47	Exhaust Elbow
48	Starter Relais (Backside E-Box Ground Plate)
49	Starter Motor
50	Flywheel
51	Flywheel Housing
52	Oil Pressure Sensor

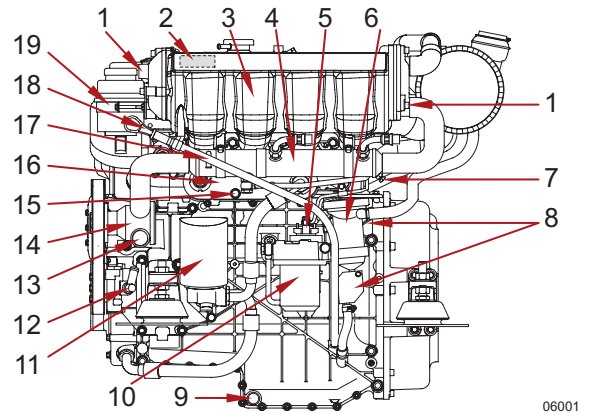

06001

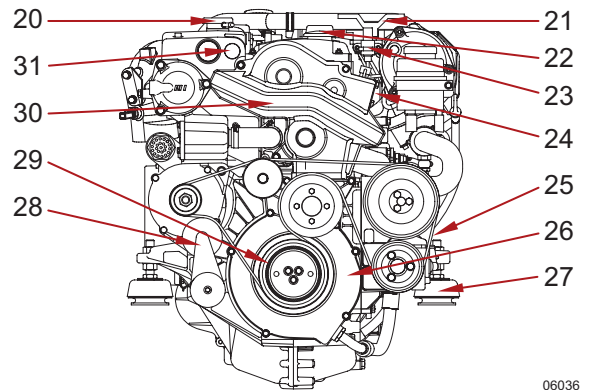

06036

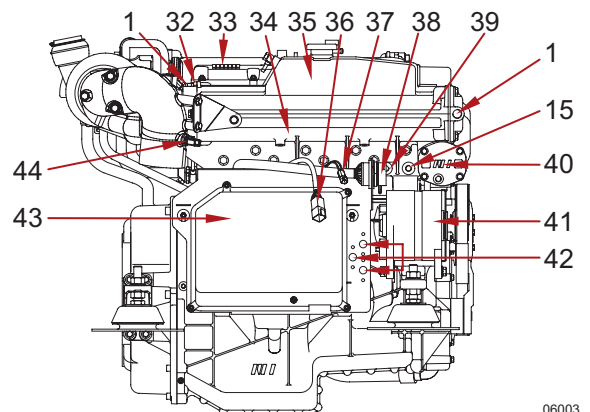

06003

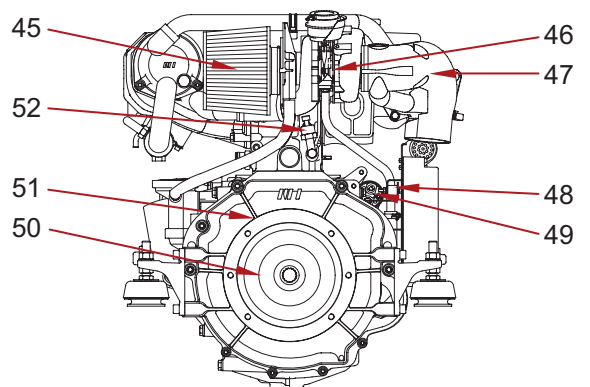

06004

\*) This sensor is magnetism sensitive. All external magnets must be kept away.

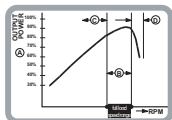

MO196K35  
MO236K42

## Technical Data and Overview MO196K35, MO236K42

MAKE	STEYR MOTORS M 16 TCM, TCAM	
type	MO196K35	MO236K42
displacement	3,200 cm <sup>3</sup>	
piston displacement	85.0 x 94.0 mm	
rated power acc. EN ISO 8665:2006 (impeller*) KW/HP Jet – Drive/Inboard Z – Drive	136/182 134/179	165/221 162/218
number of cylinders	6-cylinder in-line engine (position of cyl. 1 at vibration damper side)	
ignition order	1 – 5 – 3 – 6 – 2 – 4	
sense of rotation, seen from front	right	
compression ratio	17.5:1	
full-load speed range (rpm)	3,500 rpm (+0 rpm/–200 rpm)	4,200 rpm (+0 rpm/–300 rpm)
idle speed	630 rpm (adjustable)	
injection	Plunger activated, two stage, high pressure with electronically controlled injection rate	
fuel	acc. to CEC RF-03-A-84 (DIN EN 590) Cetan >49; diesel fuel No. 2-D, temperature above –7 °C; No.1-D, temperature below –7 °C	
fuel filter	refer to spare part catalogue	
fuel filter location	suction-sided	
air filter	refer to spare part catalogue	
oil pressure above 2,000 rpm	400 – 700 kPa (58 – 101 PSI) microprocessor controlled	
filling capacity motor oil	approx. 12.0 l engine housing (incl. approx. 1 l oil filter contents)	
specification motor oil	SAE 5W-50/ACEA B4-02/API CF or 10W-40/ACEA E4, E5, E7/API CF P/N0. Z010058/0	
oil and oil filter change intervals**)	every 150 operating hours and/or once per season	
oil filter	refer to spare part catalogue	
oil filter location	suction-sided	
electric charging system	14 V/90 A alternator with transistorized voltage regulator	
cooling system	dual cooling circuit; thermostat-controlled, pressurized cooling circuit; circulating pump with heat exchanger on engine; governor pump, external raw water circuit to heat exchange	
coolant capacity	13.2 liters	
coolant	STEYR MOTORS engine coolant –36 °C P/No. Z011785/0	

\*) Efficiency of gearbox = 97.0 %, efficiency of Z-Drive = 95.5 %

\*\*\*) Extended periods to be evaluated upon application and type of usage STEYR MOTORS GmbH.  
Reserves the right to make changes without notice or obligations.

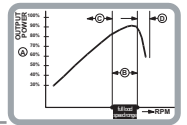

**Overview STEYR MOTORS MO196K35, MO236K42**

Item	Designation
1	Boost Pressure Sensor
2	Zinc Anode (5 Units)
3	Intercooler
4	Fuel-/Hydr. Oil Cooler
5	Engine Oilcooler
6	Model and Serial Number
7	Oil Seperator
8	Raw Water Drain Plug
9	Valve Crankshaft Housing Ventilation (only SOLAS)
10	Fuel Filter
11	Fuel Pump
12	Oil Filter
13	Raw Water Inlet Fitting
14	Raw Water Pump
15	Coolant Drain Plug (2 Units)
16	Oil Suction Pipe
17	Oil Dipstick
18	Rack Position Sensor*)
19	Engine Lifting Eye
20	Motor Oil Filler Cap
21	Potentiometer Accelerator
22	Drive Belt, Raw Water Pump
23	Engine Mount
24	Drive Belt Tensioner
25	Cover T-Belt, Lower
26	Vibration Damper
27	Drive Belt, Alternator & Hydr: Pump
28	Speed Sensor
29	Cover T-Belt, Upper
30	Valve Cover
31	Heat Exchanger
32	Coolant Expansion Tank
33	Cooler Cap
34	Diagnostic Outlet
35	Inversion Switch (only for SOLAS)
36	Connector Instrument Panel
37	Coolant Temperature Sensor
38	Thermostat Housing
39	Hydraulic Oil Tank
40	Circuit Breakers
41	Alternator
42	Hydraulic Pump
43	Oil Drain Plug
44	Starter Motor
45	Engine Management System/Fuses
46	Exhaust Temperature Sensor
47	Air Filter
48	Turbo Charger
49	Exhaust Elbow
50	Starter Relais (Backside E-Box Ground Plate)
51	Flywheel
52	Flywheel Housing
53	Oil Pressure Sensor

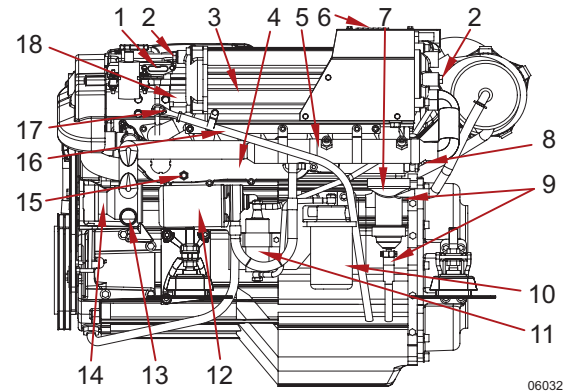

06032

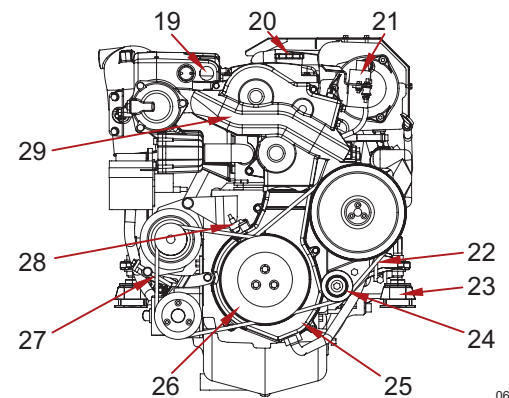

06033

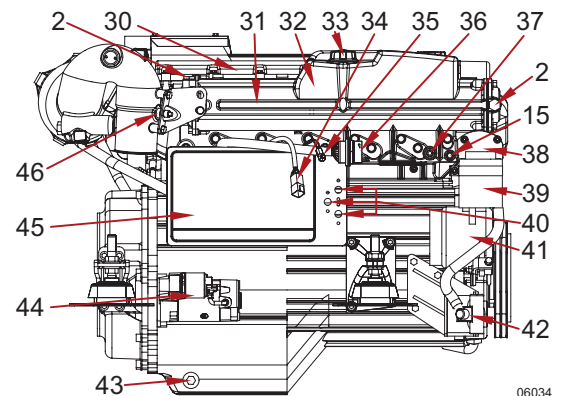

06034

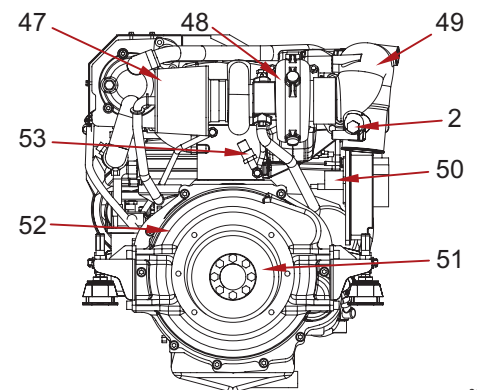

06035

\*) This sensor is magnetism sensitive. All external magnets must be kept away.

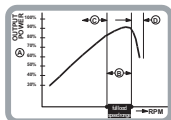

MO256K43  
MO256H45

## Technical Data and Overview MO256K43, MO256H45

MAKE	STEYR MOTORS M 16 TCAM	
type	MO256K43	MO256H45
displacement	3,200 cm <sup>3</sup>	
piston displacement	85.0 x 94.0 mm	
rated power acc. EN ISO 8665:2006 (impeller*) KW/HP Jet – Drive/Inboard Z – Drive	178/239 176/236	178/239 176/236
number of cylinders	6-cylinder in-line engine (position of cyl. 1 at vibration damper side)	
ignition order	1 – 5 – 3 – 6 – 2 – 4	
sense of rotation, seen from front	right	
compression ratio	17.5:1	
full-load speed range (rpm)	4,300 rpm (+0 rpm/–300 rpm)	4,500 rpm (+0 rpm/–300 rpm)
idle speed	630 rpm (adjustable)	
injection	Plunger activated, two stage, high pressure with electronically controlled injection rate	
fuel	acc. to CEC RF-03-A-84 (DIN EN 590) Cetan >49; diesel fuel No. 2-D, temperature above –7 °C; No.1-D, temperature below –7 °C	
fuel filter	refer to spare part catalogue	
fuel filter location	suction-sided	
air filter	refer to spare part catalogue	
oil pressure above 2,000 rpm	400 – 700 kPa (58 – 101 PSI) microprocessor controlled	
filling capacity motor oil	approx. 12.0 l engine housing (incl. approx. 1 l oil filter contents)	
specification motor oil	SAE 5W-50/ACEA B4-02/API CF or 10W-40/ACEA E4, E5, E7/API CF P/N0. Z010058/0	
oil and oil filter change intervals**)	every 150 operating hours and/or once per season	
oil filter	refer to spare part catalogue	
oil filter location	suction-sided	
electric charging system	14 V/90 A alternator with transistorized voltage regulator	
cooling system	dual cooling circuit; thermostat-controlled, pressurized cooling circuit; circulating pump with heat exchanger on engine; governor pump, external raw water circuit to heat exchange	
coolant capacity	13.2 liters	
coolant	STEYR MOTORS engine coolant –36 °C P/No. Z011785/0	

\*) Efficiency of gearbox = 97.0 %, efficiency of Z-Drive = 95.5 %

\*\*\*) Extended periods to be evaluated upon application and type of usage STEYR MOTORS GmbH.  
Reserves the right to make changes without notice or obligations.



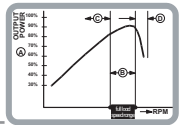

**Overview STEYR MOTORS MO256K43, MO256H45**

Item	Designation
1	Boost Pressure Sensor
2	Zinc Anode (5 Units)
3	Intercooler
4	Engine Oil/Fuel/Hydr. Oil Cooler
5	Model and Serial Number
6	Oil Seperator
7	Raw Water Drain Plug
8	Valve Crankshaft Housing Ventilation (only SOLAS)
9	Fuel Filter
10	Fuel Pump
11	Oil Filter
12	Raw Water Inlet Fitting
13	Raw Water Pump
14	Coolant Drain Plug (2 Units)
15	Oil Suction Pipe
16	Oil Dipstick
17	Rack Position Sensor*)
18	Engine Lifting Eye
19	Motor Oil Filler Cap
20	Potentiometer Accelerator
21	Drive Belt, Raw Water Pump
22	Engine Mount
23	Drive Belt Tensioner
24	Cover T-Belt, Lower
25	Vibration Damper
26	Drive Belt, Alternator & Hydr: Pump
27	Speed Sensor
28	Cover T-Belt, Upper
29	Valve Cover
30	Heat Exchanger
31	Coolant Expansion Tank
32	Cooler Cap
33	Diagnostic Outlet
34	Inversion Switch (only for SOLAS)
35	Connector Instrument Panel
36	Coolant Temperature Sensor
37	Thermostat Housing
38	Hydraulic Oil Tank
39	Circuit Breakers
40	Alternator
41	Hydraulic Pump
42	Oil Drain Plug
43	Starter Motor
44	Engine Management System/Fuses
45	Exhaust Temperature Sensor
46	Air Filter
47	Turbo Charger
48	Exhaust Elbow
49	Starter Relais (Backside E-Box Ground Plate)
50	Flywheel
51	Flywheel Housing
52	Oil Pressure Sensor

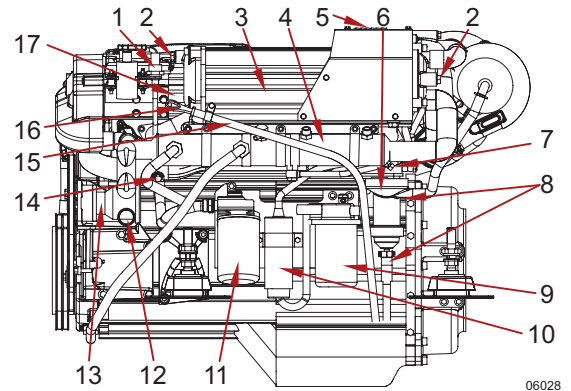

06028

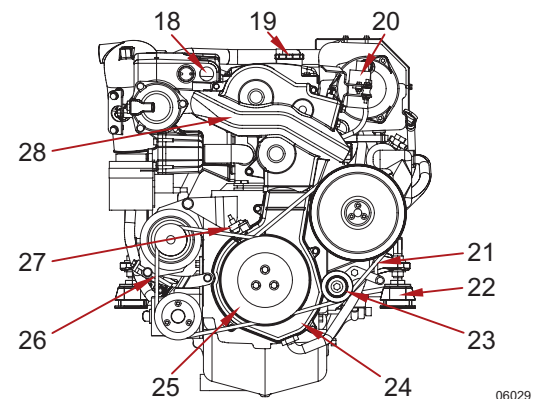

06029

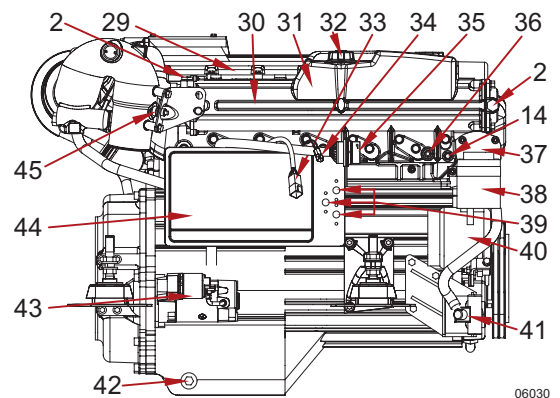

06030

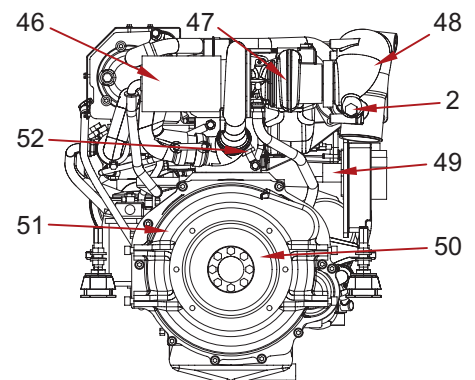

06031

\*) This sensor is magnetism sensitive. All external magnets must be kept away.

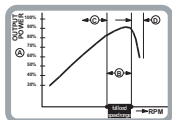

MO286H43  
MO156K25  
MO126K25

## Technical Data and overview MO286H43, MO156K25, MO126K25

MAKE	STEYR MOTORS M 16 TCAM		
type	MO286H43	MO156K25	MO126K25
displacement	3,200 cm <sup>3</sup>		
piston displacement	85.0 x 94.0 mm		
rated power acc. EN ISO 8665:2006 (impeller*) KW/HP Jet – Drive/Inboard Z – Drive	199/270 196/266	107/145 105/143	85/116 84/114
number of cylinders	6-cylinder in-line engine (position of cyl. 1 at vibration damper side)		
ignition order	1 – 5 – 3 – 6 – 2 – 4		
sense of rotation, seen from front	right		
compression ratio	17.0:1		
full-load speed range (rpm)	4,300 rpm (+0 rpm/–300 rpm)	2,500 rpm (+0 rpm/–200 rpm)	2,500 rpm (+0 rpm/–200 rpm)
idle speed	630 rpm (adjustable)		
injection	Plunger activated, two stage, high pressure with electronically controlled injection rate		
fuel	acc. to CEC RF-03-A-84 (DIN 51601) Cetan >45; diesel fuel No. 2-D, temperature above –7 °C; No.1-D, temperature below –7 °C		
fuel filter	refer to spare part catalogue		
fuel filter location	intake-sided		
air filter	refer to spare part catalogue		
oil pressure above 2,000 rpm	400 – 700 kPa (58 – 101 PSI) microprocessor controlled		
filling capacity motor oil	approx. 12.0 l engine housing (incl. approx. 1 l oil filter contents)		
specification motor oil	SAE 5W-50/ACEA B4-02/API CF or 10W-40/ACEA E4, E5, E7/API CF P/N0. Z010058/0		
oil and oil filter change intervals**)	every 150 operating hours and/or once per season		
oil filter	refer to spare part catalogue		
oil filter location	pressure-sided		
electric charging system	14 V/90 A alternator with transistorized voltage regulator		
cooling system	dual cooling circuit; thermostat-controlled, pressurized cooling circuit; circulating pump with heat exchanger on engine; governor pump, external raw water circuit to heat exchange		
coolant capacity	13.2 liters		
coolant	STEYR MOTORS engine coolant –36 °C P/No. Z011785/0		

\*) Efficiency of gearbox = 97.0 %, efficiency of Z-Drive = 95.5 %

\*\*\*) Extended periods to be evaluated upon application and type of usage STEYR MOTORS GmbH.  
Reserves the right to make changes without notice or obligations.

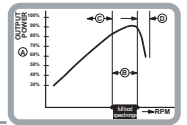

**Overview STEYR MOTORS MO286H43, MO156K25, MO126K25**

Item	Designation
1	Boost Pressure Sensor
2	Zinc Anode
3	Intercooler
4	Fuel/Hydr. Oil Cooler
5	Model and Serial Number
6	Oil Seperator
7	Raw Water Drain Plug
8	Valve Crankshaft Housing Ventilation (only SOLAS)
9	Fuel Filter and water seperator
10	Fuel Pump
11	Oil Filter
12	Raw Water Inlet Fitting
13	Raw Water Pump
14	Coolant Drain Plug (2 Units)
15	Oil Suction Pipe
16	Oil Dipstick
17	Rack Position Sensor*)
18	Engine Lifting Eye
19	Motor Oil Filler Cap
20	Potentiometer Accelerator
21	Drive Belt, Raw Water Pump, Alternator, Hydr. Pump
22	Engine Mount
23	Drive Belt Tensioner
24	Cover T-Belt, Lower
25	Vibration Damper
26	Speed Sensor
27	Cover T-Belt, Upper
28	Valve Cover
29	Heat Exchanger
30	Coolant Expansion Tank
31	Cooler Cap
32	Diagnostic Outlet
33	Inversion Switch (only for SOLAS)
34	Connector Instrument Panel
35	Coolant Temperature Sensor
36	Thermostat Housing
37	Hydraulic Oil Tank
38	Circuit Breakers
39	Alternator
40	Hydraulic Pump
41	Oil Drain Plug
42	Starter Motor
43	Engine Management System/Fuses
44	Exhaust Temperature Sensor
45	Air Filter
46	Turbo Charger
47	Exhaust Elbow
48	Starter Relais (Backside E-Box Ground Plate)
49	Flywheel
50	Flywheel Housing
51	Oil Pressure Sensor
52	Water drain point

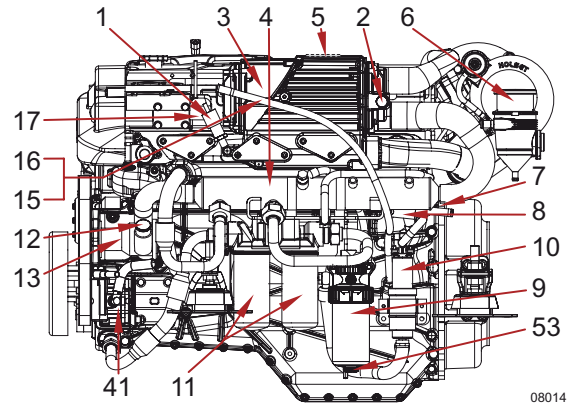

08014

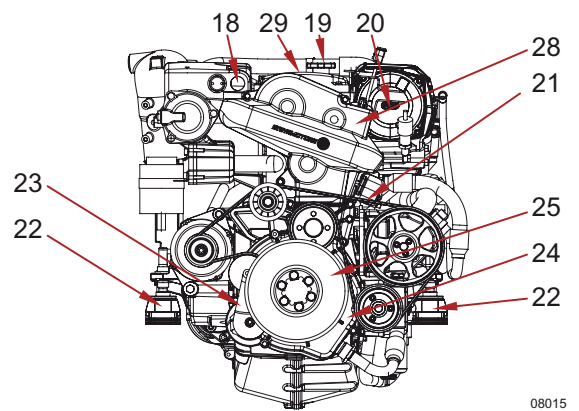

08015

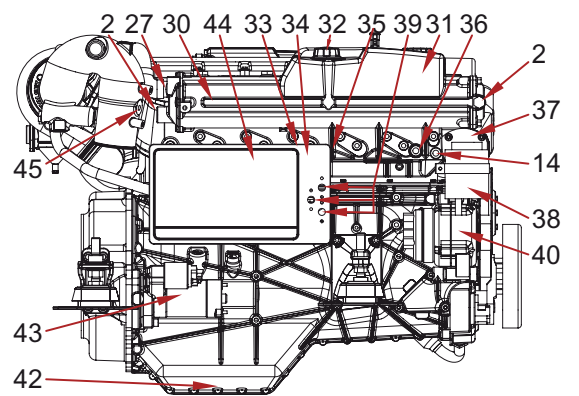

08016

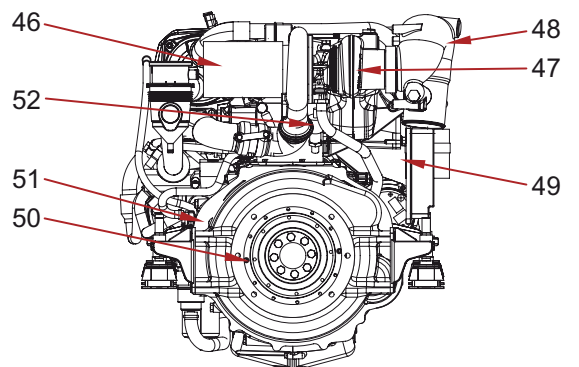

08017

\*) This sensor is magnetism sensitive. All external magnets must be kept away.

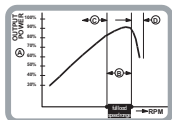

**Technical data and overview MO306H43WJ**

MAKE	STEYR MOTORS M 16 TCAM
type	MO306H43WJ
displacement	3,200 cm <sup>3</sup>
piston displacement	85.0 x 94.0 mm
rated power acc. EN ISO 8665:2006 (impeller*) KW/HP Jet – Drive/Inboard	209/284
number of cylinders	6-cylinder in-line engine (position of cyl. 1 at vibration damper side)
ignition order	1 – 5 – 3 – 6 – 2 – 4
sense of rotation, seen from front	right
compression ratio	17-0:1
full-load speed range (rpm)	4,300 rpm (+0 rpm/–300 rpm)
idle speed	630 rpm (adjustable)
injection	Plunger activated, two stage, high pressure with electronically controlled injection rate
fuel	acc. to CEC RF-03-A-84 (DIN 51601) Cetan >45; diesel fuel No. 2-D, temperature above –7 °C; No.1-D, temperature below –7 °C
fuel filter	refer to spare part catalogue
fuel filter location	intake-sided
air filter	refer to spare part catalogue
oil pressure above 2,000 rpm	400 – 700 kPa (58 – 101 PSI) microprocessor controlled
filling capacity motor oil	approx. 12.0 l engine housing (incl. approx. 1 l oil filter contents)
specification motor oil	SAE 5W-50/ACEA B4-02/API CF or 10W-40/ACEA E4, E5, E7/API CF P/N0. Z010058/0
oil and oil filter change intervals**)	every 150 operating hours and/or once per season
oil filter	refer to spare part catalogue
oil filter location	pressure-sided
electric charging system	14 V/90 A alternator with transistorized voltage regulator
cooling system	dual cooling circuit; thermostat-controlled, pressurized cooling circuit; circulating pump with heat exchanger on engine; governor pump, external raw water circuit to heat exchange
coolant capacity	13.2 liters
coolant	STEYR MOTORS engine coolant –36 °C P/No. Z011785/0

\*) Efficiency of gearbox = 97.0 %, efficiency of Z-Drive = 95.5 %

\*\*\*) Extended periods to be evaluated upon application and type of usage STEYR MOTORS GmbH.  
Reserves the right to make changes without notice or obligations.

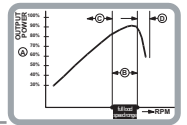

**Overview STEYR MOTORS MO306H43WJ**

Item	Designation
1	Boost Pressure Sensor
2	Zinc Anode
3	Intercooler
4	Fuel/Hydr. Oil Cooler
5	Model and Serial Number
6	Oil Seperator
7	Raw Water Drain Plug
8	Valve Crankshaft Housing Ventilation (only SOLAS)
9	Fuel Filter and water seperator
10	Fuel Pump
11	Oil Filter
12	Raw Water Inlet Fitting
13	Raw Water Pump
14	Coolant Drain Plug (2 Units)
15	Oil Suction Pipe
16	Oil Dipstick
17	Rack Position Sensor*)
18	Engine Lifting Eye
19	Motor Oil Filler Cap
20	Potentiometer Accelerator
21	Drive Belt, Raw Water Pump, Alternator, Hydr. Pump
22	Engine Mount
23	Drive Belt Tensioner
24	Cover T-Belt, Lower
25	Vibration Damper
27	Speed Sensor
28	Cover T-Belt, Upper
29	Valve Cover
30	Heat Exchanger
31	Coolant Expansion Tank
32	Cooler Cap
33	Diagnostic Outlet
34	Inversion Switch (only for SOLAS)
35	Connector Instrument Panel
36	Coolant Temperature Sensor
37	Thermostat Housing
38	Hydraulic Oil Tank
39	Circuit Breakers
40	Alternator
41	Hydraulic Pump
42	Oil Drain Plug
43	Starter Motor
44	Engine Management System/Fuses
45	Exhaust Temperature Sensor
46	Air Filter
47	Turbo Charger
48	Exhaust Elbow
49	Starter Relais (Backside E-Box Ground Plate)
50	Flywheel
51	Flywheel Housing
52	Oil Pressure Sensor
53	Water drain point

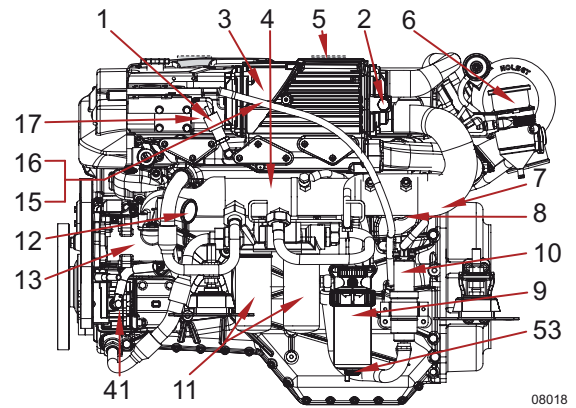

08018

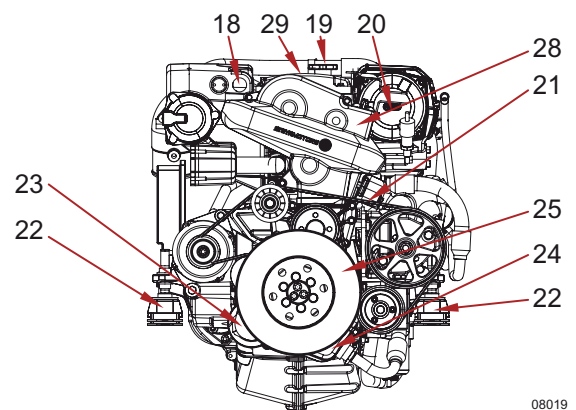

08019

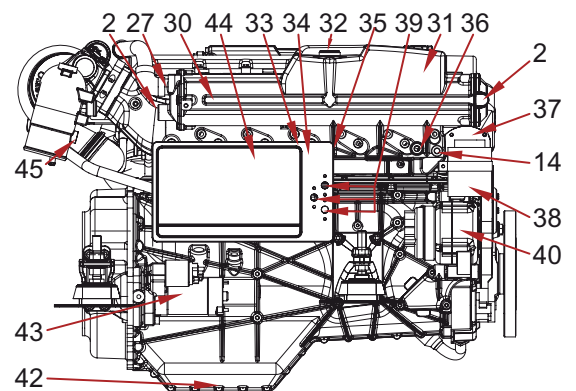

08020

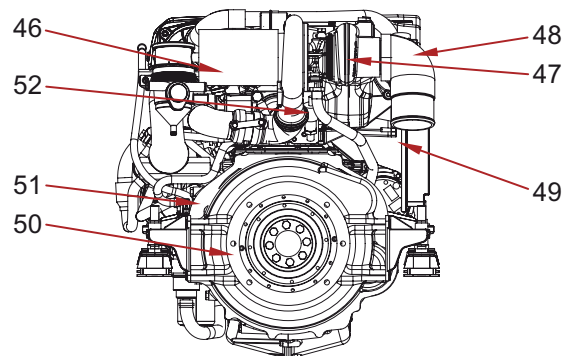

08021

\*) This sensor is magnetism sensitive. All external magnets must be kept away.

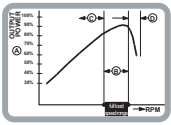

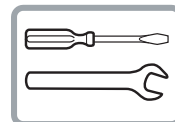

## MAINTENANCE AND TROUBLE SHOOTING

Owner Service Log .....	65
FOREWORD .....	65
IMPORTANT NOTE .....	65
Service- and Maintenance Schedule .....	66
MAINTENANCE LOG .....	68
Table – Error Indication on Instrument Panel .....	70
Table – Error Indication on Instrument Panel (for SOLAS only) .....	72
Reading Service Codes .....	74
Indication and Cancellation of memorised sensor and circuit faults .....	75
Selection and clearing of stored service codes: .....	75
Principle service code list .....	76
Trouble Check Chart .....	78
Wiring harness .....	80
WIRING DIAGRAM/MARINE BASE – 4/6 CYLINDER – 12 V .....	81
WIRING DIAGRAM/MARINE – 4/6 CYLINDER – 2-POLE – 12 V (OPTION) .....	82
WIRING DIAGRAM/MARINE – 4/6 CYLINDER – 24 V (OPTION) .....	83
WIRING DIAGRAM/MARINE – 4/6 CYLINDER – 2-POLE – 24 V – COMPLETE SYSTEM .....	84
Description – Wiring harness instrument panels 4/6 cyl. marine engines (current version) .....	85
WIRING DIAGRAM/INSTRUMENT CAN PANEL – 4/6 CYLINDER – 12 V .....	86
WIRING DIAGRAM/INSTRUMENT CAN PANEL – 4/6 CYLINDER – 24 V (OPTION) .....	87
WIRING DIAGRAM/INSTRUMENT CAN PANEL – 4/6 CYLINDER – Solus – 12 V (OPTION) .....	88

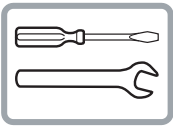



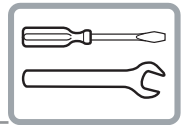

## Owner Service Log

### FOREWORD

On receipt of your new **STEYR MOTORS Marine Engine**, the authorised dealer has signed the pre-delivery inspection log thus confirming to have carried out a pre-delivery service according to the manufacturers specifications.

Future service requirements are indicated in this **OWNER SERVICE LOG**. When these services are carried out, the STEYR MOTORS Marine dealer will stamp the respective stubs. This servicing will assist in maintaining the value and satisfactory operation of your **STEYR MOTORS Marine Engine**.

It lies in the owner's interest that for maintaining warranty and best performance of his **STEYR MOTORS Marine Engine** he always insists on the sole utilization of **STEYR MOTORS – ORIGINAL** replacement parts, operational fluids and lubricants as well as STEYR MOTORS proved service procedures!

It is important that you study this booklet carefully as it will assist you in achieving satisfaction from your **STEYR MOTORS Marine Engine**. Please retain this manual in the boat as it **MUST** be presented to the **STEYR MOTORS Marine dealer** whenever you require **WARRANTY** and/or **SERVICE**.

### IMPORTANT NOTE

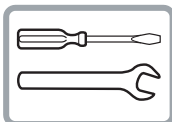

This manual contains all service activities required for your engine. Checks and maintenance for the other parts of a complete drive system still need to be completed. Any such procedures are to be found in separate, attached booklet(s) of the individual manufacturer's literature provided with the gearbox or similar drive components.

Whenever this manual refers to components like Manual Operation, Hydraulic Pump, etc., such instructions only apply where applicable since they are not used on every engine model.

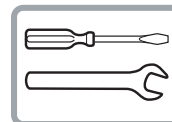

Service- and Maintenance Schedule			daily	after first 50 hours or 6 months	every 150 h. or 12 months	every 300 h. or 24 months	*) notes	
ENGINE LUBRICATION	check	– for leakage – oil level	●					
	change	– oil filter – motor oil		●	●			
ENGINE COOLING SYSTEM	check	– for leakage	●					
		– fluid level	●					
		– hoses, hose clamps – antifreeze temperature condition	●		●			
	change	– antifreeze*)					every 24 month	
RAW WATER SYSTEM	check	– hoses, hose clamps	●					
		– zinc anodes		●	●			
		– raw water pump V-belt – impeller	●			●		
	change	– raw water pump V-belt*) – impeller*)				●		if required
		– zinc anodes*)				●		if required
preserve	– raw water circuit*)				●		if corroded >50 % after season	
RAW WATER COOLER (OIL-FUEL-AUX. LUBRICANT) for 246/256 and 266, 286, 306, 126, 156 only	check	– raw water passages*)				●	clean out desposits in pipelines	
	change	– zinc anodes*)				●	required if more than 50 % material corroded	
AIR FILTER	check	– contamination	●					
	change	– air filter element				●		
	preserve						after season	
FUEL SYSTEM	check	– for leakage – hoses	●		●	●		
	drain	– additional fuel filter		●	●			
	change	– fuel filter		●		●		
	check	– additional fuel filter		●	●			
	preserve	– fuel system*)					after season	
BATTERY	check	– acid level		●	●			
		– density		●	●			
ELECTRONICS	check	– connections*)					after season	
ELECTRICAL EQUIPMENT	check	– connections		●	●		tighten loose connections. Renew cables, if required.	
		– insulation		●	●			
INVERSION SWITCH	check (Solus only)	– switch*)		●			every 50 hours or every 6 months	
DRIVING SYSTEM	re-center	– driving unit*)		●	●		see manufacturer's specifications	
V-BELT	check	– generator & impeller pump		●	●		adjust tension	
		– power-steering		●	●		adjust tension	
	change	– generator*) – power-steering*)				● ●	if required if required	
POLY-V-BELT (SERPENTINE BELT) for 4 and 286, 306, 126, 156 models	check	– belt, pulleys and tighteners for wear		●	●			
	change	– Poly -V-belt					every 1,050 hours or every 48 months	



Service- and Maintenance Schedule			daily	after first 50 hours or 6 months	every 150 h. or 12 months	every 300 h. or 24 months	*) notes
<b>POLY-V-BELT TENSION</b>	check			●	●		
	change				●		
<b>GLOW PLUGS</b>	change	– plugs*)					every 1,500 h. or every 48 months
<b>TIMING BELT</b>	check	– belt tension		●	●		
	change	– timing belt*)					every 1,500 h. or every 48 months
		– water pump, tensioner					every 1,500 h. or every 48 months
<b>VALVES</b>	check	– valve clearance*)		●			every 750 hours
<b>ENGINE TIMING</b>	check	– set timing					every 750 hours
<b>UNIT INJECTOR</b>	check	– set levers*)		●			every 750 hours
		– set point		●			every 750 hours
		– tighten torque		●			every 750 hours
<b>POWER STEERING PUMP OR LOAD SENSING HYDR. PUMP</b>	check	– oil level	●				
		– for leakage	●				
	change	– hydraulic oil (ATF)*)				●	every 750 h. or every 24 months
<b>GEARBOX-STERNDRIVE</b>	check	– oil level	●				
		– for leakage	●				
	change	– gear oil (ATF)*) – oil filter					see manufacturer's specifications
<b>FRONT VIBRATION DAMPER</b>	check	– torque		●		●	
<b>ENGINE COMPARTMENT AND BILGE</b>	check for	– leakage – water	●				repair or consult your STEYR MOTORS Marine dealer
		– fuel	●				
		– exhaust gas	●				
<b>SHIFTING</b> 	check	– smooth action	●				If required, to be replaced by your STEYR MOTORS Marine Dealer
		– adjustment	●				
<b>STEERING</b> 	check	– lubrication	●				see manufacturer's specifications
		– oil level	●				
<b>SAFETY EQUIPMENT</b> 	check	– remote control	●				local rules and consultation of your STEYR MOTORS Marine Dealer
		– emergency cutout	●				
		– completeness	●				
		– condition	●				
<b>SHAFT BEARING GLAND</b>	check	– lubrication	●				consult STEYR MOTORS Marine Dealer
		– sealing	●				
<b>ENGINE MOUNT SCREWS</b>	check	– torque*)		●			every 750 hours
<b>WARNING DEVICE</b>	check	– function		●	●		

**Sticker of 1<sup>st</sup> preservation**  
(refer to Installation Manual P/N Z001007-0/  
Chapter 18/Installation and pre-delivery  
inspection report)

*Date:*

**Sticker of 2<sup>nd</sup> preservation**

*Date:*

**Sticker of 3<sup>rd</sup> preservation**

*Date:*

**Commissioning**

*Date:*

**50 h Service**

Made by:

*Date:*

**150 h Service**

Made by:

*Date:*

**300 h Service**

Made by:

*Date:*

**450 h Service**

Made by:

*Date:*

**600 h Service**

Made by:

*Date:*

**750 h Service**

Made by:

*Date:*

**900 h Service**

Made by:

*Date:*

**1,050 h Service**

Made by:

*Date:*



**1,200 h Service**

Made by:

Date:

**1,350 h Service**

Made by:

Date:

**1,500 h Service**

Made by:

Date:

**1,650 h Service**

Made by:

Date:

**1,800 h Service**

Made by:

Date:

**1,950 h Service**

Made by:

Date:

**2,100 h Service**

Made by:

Date:

**2,250 h Service**

Made by:

Date:

**2,400 h Service**

Made by:

Date:

**2,550 h Service**

Made by:

Date:

**2,700 h Service**

Made by:

Date:

**2,850 h Service**

Made by:

Date:

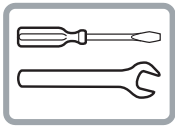



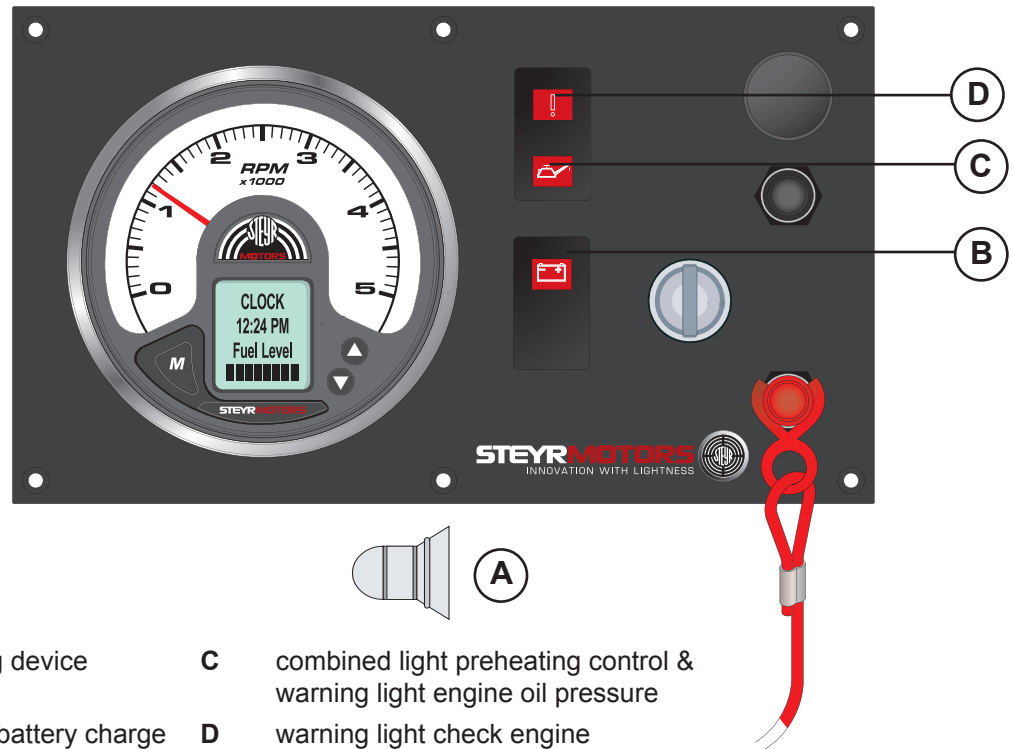
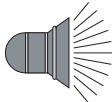





**Table – Error Indication on Instrument Panel**









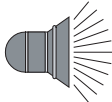

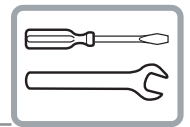

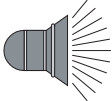



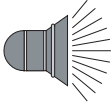



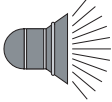

- A** audible warning device      **C** combined light preheating control & warning light engine oil pressure  
**B** warning light – battery charge      **D** warning light check engine

**Operating condition:** During normale engine operation, or indication in case of sensor defect while ignition is switched ON.

**Event:**  Speed resp. performance limitation during engine operation

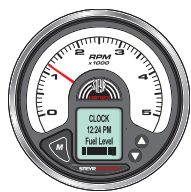
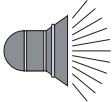
Indication status			Fault	Remarks
80° – 90 °C		OFF	<b>oil pressure below min. limit</b>	check oil level, contact authorized workshop
<b>ON</b>		<b>ON</b>		
		OFF		
80° – 90°C		OFF	<b>fault oil pressure sensor or sensor connection</b>	check oil level, contact authorized workshop
		<b>FLASHING (1x per sec.)</b>		
OFF		OFF		
<b>ON</b>		<b>ON</b>	<b>engine overload during break-in period</b>	reduce throttle position until light goes OFF (indication during first 2 hours of operation) see “engine break in procedure”
				



Indication status			Fault	Remarks
80° – 90 °C <b>ON</b>  (2x per sec.)	 <b>FLASHING</b> (2x per sec.)  OFF  OFF	OFF OFF OFF	high exhaust temperature (over 80 °C) or defect exhaust temperature sensor or bad connection	check raw water system, strainer, impeller pump contact authorized workshop
high approx 105 °C <b>ON</b>  (2x per sec.)	 OFF  OFF  OFF	OFF OFF OFF	engine coolant temperature too high	after cooling down, check engine coolant level contact authorized workshop
120 °C <b>ON</b>  (2x per sec.)	 OFF  OFF  OFF	OFF OFF OFF	defect engine coolant sensor or bad connection	after cooling down, check engine coolant level contact authorized workshop
80° – 90 °C <b>OFF</b> 	 OFF  OFF  OFF	OFF OFF OFF	unstable idle speed, no indication on tachometer 	defect speed sensor or sensor connection contact authorized workshop
80° – 90 °C <b>ON</b>  (2x per sec.)	 <b>ON</b>  OFF  OFF	<b>ON</b> OFF OFF	Trouble in governing loop, involved components: control solenoid, rack, control gear of unit injector, rack position sensor	contact authorized workshop

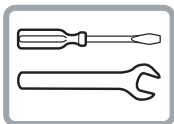
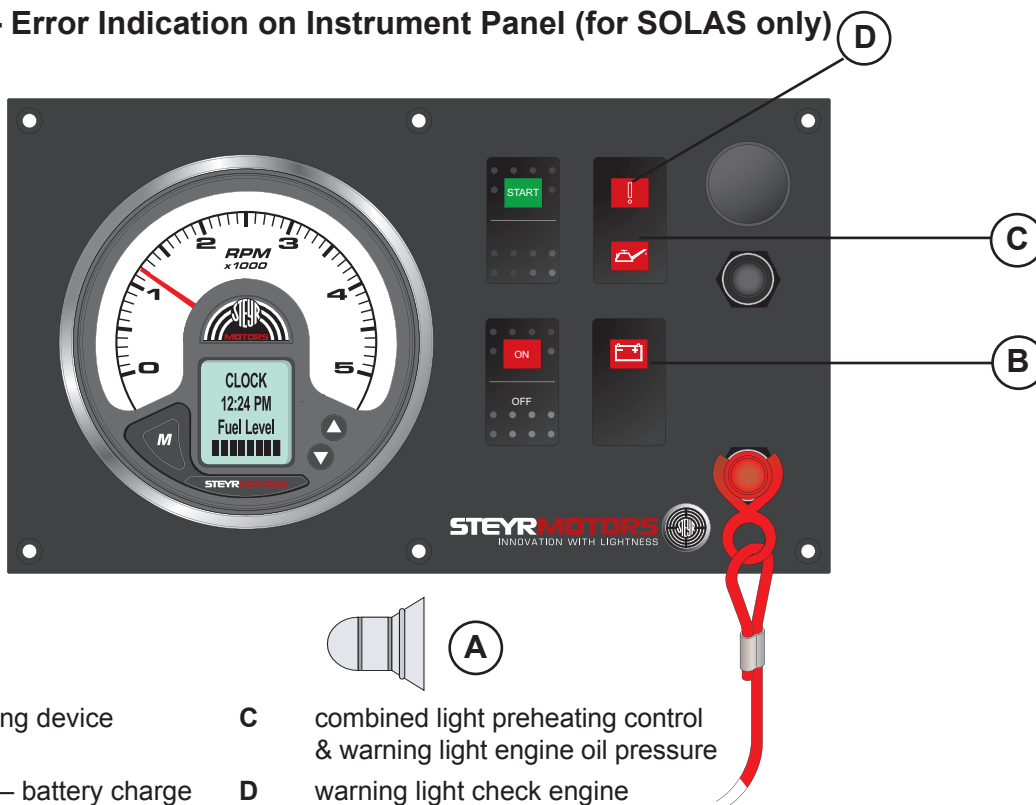

Table – Error Indication on Instrument Panel (for SOLAS only)



**A** audible warning device

**C** combined light preheating control & warning light engine oil pressure

**B** warning light – battery charge

**D** warning light check engine

**Operating condition:**

During normale engine operation, or indication in case of sensor defect while ignition is switched ON.









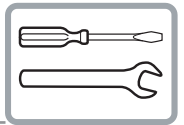

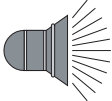



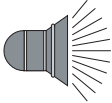



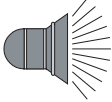

**Event:**

Speed resp. performance limitation during engine operation

Indication status			Fault	Remarks
80° – 90 °C		OFF	<b>oil pressure below min. limit</b>	check oil level, contact authorized workshop
<b>ON</b>		<b>ON</b>		
		OFF		
80° – 90°C		OFF	<b>fault oil pressure sensor or sensor connection</b>	check oil level, contact authorized workshop
OFF		<b>FLASH-ING (1x per sec.)</b>		
		OFF		
<b>ON</b>		<b>ON</b>	<b>engine overload during break-in period</b>	reduce throttle position until light goes OFF (indication during first 2 hours of operation) see “engine break in procedure”

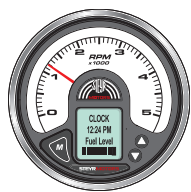
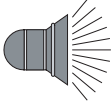



Indication status			Fault	Remarks
80° – 90 °C <b>ON</b>  (2x per sec.)	 <b>FLASHING</b> (2x per sec.)  OFF  OFF		<b>high exhaust temperature (over 80 °C) or defect exhaust temperature sensor or bad connection</b>	check raw water system, strainer, impeller pump contact authorized workshop
high approx 105 °C <b>ON</b>  (2x per sec.)	 OFF  OFF  OFF		<b>engine coolant temperature too high</b>	after cooling down, check engine coolant level contact authorized workshop
120 °C <b>ON</b>  (2x per sec.)	 OFF  OFF  OFF		<b>defect engine coolant sensor or bad connection</b>	after cooling down, check engine coolant level contact authorized workshop
80° – 90 °C <b>OFF</b> 	 OFF  OFF  OFF		<b>unstable idle speed, no indication on tachometer</b> 	defect speed sensor or sensor connection contact authorized workshop
80° – 90 °C <b>ON</b> 	 <b>ON</b>  OFF  OFF		<b>Trouble in governing loop, involved components: control solenoid, rack, control gear of unit injector, rack position sensor</b>	contact authorized workshop

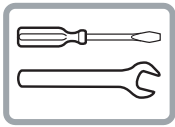

## Reading Service Codes

### Entering and reading of stored faults via Check Engine Lamp and Diagnostic Outlet Plug (X23):

- 18** Needed device:  
Tool VR00135/1  
(normally closed push button switch)  
connected to Diagnostic Outlet Plug X23.

In case this tool is not available:  
Connect temporarily Pin – Pos. 1 with Pin – Pos. 2  
of Diagnostic Plug X23  
(before ignition is turned on at key switch)

Connect as above and turn the ignition on to enter error indication mode.

### Code indication and indication sequence:

After entering the service code indication modus the Engine Management System will display a blink code at the Check Engine Light on the dash panel. The blinking sequence will always begin and end with control code indication # 12. Each service code will be repeated **3** times to assure your correct reading – see below bar code illustration.

Example sequence check engine light: Service code # 14

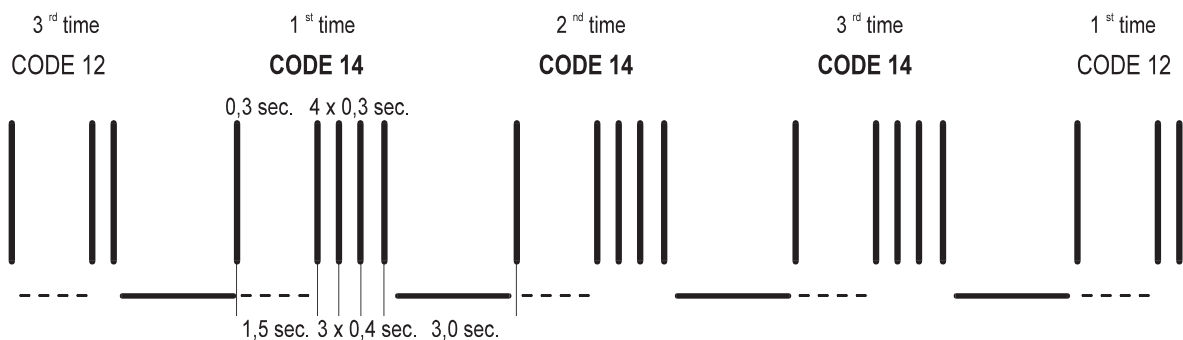

- Stroke = Check Engine Light illuminated for 0.3 sec. (Light Off – period within blink sequence 0.4 sec.)
- Dashed Line = interruption within code indication 1.5 sec.
- Solid Line = interval interruption between service code 3.0 sec.

If more then one service code is stored in the Engine Management System the indication sequence will be continued blinking additional stored error codes. To delete a memorized service code see description Indication and Cancellation of memorized sensor and circuit faults.

For a description of the possible service codes refer to enclosed Table – Service Codes

**ATTENTION:** To exit from Service code indication. Tool VR00135/1 must be removed (connection between Pin 1 to Pin 2 opened) before ignition is turned ON again.

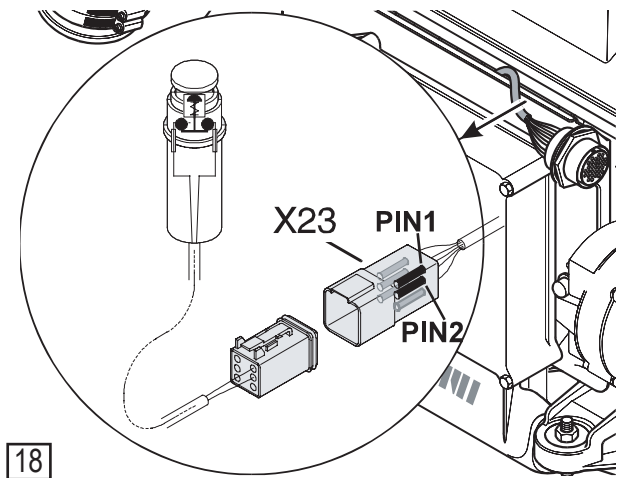

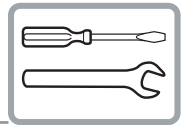

## Indication and Cancellation of memorised sensor and circuit faults

### Selection and clearing of stored service codes:

#### Procedure:

\* Ignition – OFF

\* Connect Tool VR00135/1 to Diagnostic Outlet Plug (X23)

\* Ignition – ON

**NOTE:** The program changes automatically to indication of service codes. If no service code is stored, only repeating control code reading “Code # 12” will be displayed. Possible memorized codes are indicated as shown in the previous illustrated example (blinking 3x Code # 12 i. e. 3x service code # 14 etc.) The sequence will be prolonged with additional codes if more than one service code is stored. See Table – Service codes for description

\* To delete a determined service code from the Engine Management System concentrate for the 3<sup>rd</sup> times flashing the desired service code. While this service code is displayed the third time the button (Tool VR00135/1) must be pushed and kept in this position (contact open).

\* The indication on the Check Engine Light changes to a fast blinking of the lamp (app. 4 times per sec.). During this rapid flashing light the push button must be released (close contact after app. 2 sec.) to delete this service code.

**NOTE:** Any other service code have to be selected and cleared individually following the above mentioned procedure to delete a determined service code.

**NOTE:** An service code can only be deleted if no defect exists in this circuit. In case of a present active failure, the service code keeps reappearing until the problem has been repaired and the circuit is properly working again.

\* Disconnect Tool VR00135/1 from Diagnostic Outlet Plug (X23) to exit from service code display.

**NOTE:** Watch indication of the Check Engine Light and the Warning Horn after ignition contact. If all service codes are deleted from the Engine Management System the indication resumes to 0.7 sec. function test of Check Engine Light and the Warning Horn. For additional details see Chart – Operating Conditions – Instrument panel.

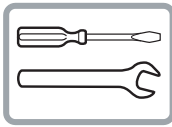

## Principle service code list

**NOTE:** Some codes may not apply due to different application!

**Chart -Service Codes (Issue 27.7.2009)** update 14.04.2010 AL

CODE	ABBREV.	150	PIN WIRE	INVOLVED DEVICE	POSSIBLE CAUSE
12	Control code				Beginning and/or end of loop; while selected in blink code mode
13	LoMap	X12/B12	Pin2 - 60112-01	boost pressure sensor	Voltage level too low (short circuit)
14	HiMap	X12/B12	Pin2 - 60112-01	boost pressure sensor	Voltage level too high (missing connection)
17	LoEXH	X17/B17	Pin1 - 60118-01	air charge temp. sensor	Resistor- signal level too low (short circuit)
18	HiEXH	X17/B17	Pin1 - 60118-01	air charge temp. sensor	Resistor- signal level too high (missing connection)
21	LoECT	X16/B16	Pin1 - 60114-01	water temperature sensor	Resistor- signal level too low (short circuit)
22	HiECT	X16/B16	Pin1 - 60114-01	Water temperature sensor	Resistor- signal level too high (missing connection)
23	LoPed1	X13/B13	Pin2 - 60111-01	Potentiometer accelerator	Signal level input too low
24	HiPed1	X13/B13	Pin2 - 60111-01	Potentiometer accelerator	Signal level input too high
25	LoVPWR	F5/K27	ECU Pin 18 - 15012-02	Main relay	Low voltage supply to ECU, F5, K27
26	HiVPWR	F5/K27	ECU Pin 18 - 15012-02	Main relay	Too high voltage on VPROT input
27	LoVREF	X5/Z3	ECU Pin 3 - 15100-03	Module, connector	Low voltage on sensor supply (short circuit, sensor or ECU defective)
28	HIVREF	X5/Z1	ECU Pin 3 - 15100-03	Module, connector	High voltage on sensor supply (short circuit, ECU defective)
29	PedS	X13/B13	Pin1,2 - 60111-01, 60112-01	Accelerator potentiometer switch	Defect on pedal safety switch, Pin 1-2
31	LoLPS	X18/B18	Pin2 - 60117-02	Lubricant pressure sensor	Voltage level too low (short circuit)
32	HiLPS	X18/B18	Pin2 - 60117-02	Lubricant pressure sensor	Voltage level too high (missing connection)
33	LoPed2	X13/B13	Pin1 - 60116-01	Potentiometer accelerator	Voltage level too low (short circuit)
34	HiPed2	X13/B13	Pin1 - 60116-01	Potentiometer accelerator	Voltage level too high (missing connection)
35	LoRPos	X14/B14	PinB - 60112-01	Rack position potentiometer	Voltage level too low (short circuit)
36	HiRPos	X14/B14	PinB - 60112-01	Rack position potentiometer	Voltage level too high (missing connection)
53	N_RFI	X15/B15	Pin2 - 60113-01	RPM-sensor	Radio interference / sensor input
54	BadSta	M1-Pin50	K28/87 - Starter motor KI.50	K28 start assist relay	No start signal from start assist solenoid while starting
55	NoPuls	X15/B15	Pin2 - 60113-01	RPM-sensor	No speed signal during crank
56	Srpos	Y14/(B14)	PinB - 60112-01	Refer to setting rack pos.	Rack calibration out of tolerance
57	Rack0	Y14/(B14)	PinB - 60112-01	Refer to setting rack position	Bad rack zero position (Y20- mechanical problem or RACK-sensor fault)
99	FMSpwm	X20/Y20	Pin1-31409-01 Pin2-15012-01	Actuator / solenoid	Defect in governor solenoid circuit (short circuit or missing connection)
161	HIVTgc	X28/Y28	Pin4- 31416	REA Unit at Turbo Charger	Defect in circuit of actuator turbo charger (short circuit)
162	LoVTgc	X28/Y28	Pin4- 31416	REA Unit at Turbo Charger	Defect in circuit of actuator turbo charger (missing connection)
164	CELS	L2	60810-01	Check engine lamp	Current limit in circuit exceeded (short circuit)
165	CELO	L2	60810-01	Check engine lamp	Missing connection or bulb blown
167	FPR_s	K24	K24/85 - 31554-01	Fuel pump relay	Current limit exceeded in relay circuit (short circuit)
168	FPR_o	K24	K24/85 - 31554-01	Fuel pump relay	No current detected in relay circuit (disconnection)
177	MR_s	K27	K27/85 - 31558-01	Main Relay	No current detected in main relay circuit (short circuit)

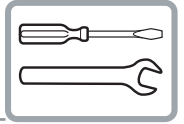

**Chart -Service Codes (Issue 27.7.2009)** update 14.04.2010 AL

CODE	ABBREV.	150	PIN WIRE	INVOLVED DEVICE	POSSIBLE CAUSE
178	MR_o	K27	K27/85 - 31558-01	Main Relay	No current detected in main relay circuit (disconnection)
181	WarnLs	L3	60616-01	Oil pressure lamp	Current limit exceeded (short circuit)
182	WarnLo	L3	60616-01	Oil pressure lamp	No current in circuit of oil pressure lamp (bulb blown or missing connection)
186	BadPos	Y20		Governor solenoid	Rack positioning fault; difference of calc. to actual rack position to high (pos. out of tolerance), common rack or injector gear rod jammed.
187	HIFMSC	X20/Y20	31409-01; 15012-01	Governor solenoid	Defect in governor wire circuit (resistance too high)
188	LoFMSC	X20/Y20	31409-01; 15012-01	Governor solenoid	Defect in governor wire circuit (resistance too low)
193	VTG_Bad	Y28	Pin4- 31416	REA Unit at Turbo Charger	Defect in output circuit (short circuit or missing connection)
194	GPR_s	K26	K26/85 - 31555-01	Glow assist relay	Current limit exceeded in glow plug relay circuit (short circuit)
195	GPR_o	K26	K26/85 - 31555-01	Glow assist relay	no current detected in glow plug relay circuit (disconnection)
201	HITEMP	---		Operation Limit exceeded - Engine Overheated	Misuse: Engine was operated with too high coolant temperature
202	Lop	---		Operation Limit exceeded - Lubricant Pressure too low	Misuse: Engine was operated with too low lubricant pressure
203	Manop	---		Operation Limit exceeded - rack position too high	Misuse: Engine operated with manual movement of rack
204	WarBJ				Misuse: Engine had been operated "without Engine monitoring
205	Ovs				Misuse: Over speed (coasting mode)
220		---		CMD-Value	CMD-Value delivered by CAN-Message invalid or missing
221		---		TRQREQ_BAD	Torque-Request by CAN-Message invalid or missing
222	NoVCU	CAN		CAN	TSC1 message from vehicle controller invalid or missing
223	NoTCU	CAN		CAN	TSC1 message from transmission controller invalid or missing
224	NoM1CUEXT	CAN		CAN	message from 2nd engine controller invalid or missing
271	HCU_offline	CAN		Hybrid Control Unit is offline	Check CAN wiring, HCU supply
272	HCU_Error	CAN		Hybrid Control Unit general error	Check HCU manual
273	HCU_overtemp	CAN		Electric unit / motor too hot	wait for cooling down, check Hybrid cooling circuit
274	HCU_system_overload	CAN		Hybrid Control Unit overloaded	Check HCU manual

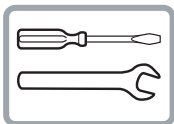

## Trouble Check Chart

**ATTENTION:**

After following the “Action” described in chart, and before cranking the engine, make sure there are no loose fuel connections. Make sure engine compartment is free of fuel vapours. Failure to do so could result in fire.



SYMPTOM	POSSIBLE CAUSE	ACTION
Engine won't start       <b>Only for SOLAS ==&gt;</b>	<ol style="list-style-type: none"> <li>1. No fuel in tank or shut-off valve closed</li> <li>2. Air leak in suction lines</li> <li>3. Fuel line plugged or pump defective</li> <li>4. Poor fuel quality</li> <li>5. Water in fuel filter</li> <li>6. System error or failure</li> <li>7. Battery output insufficient</li> <li>8. Inversion switch actuated</li> </ol>	<p>Fill tank or open valve.</p> <p>Bleed fuel system and check for leaks.</p> <p>Fuel pump may be defective. See your STEYR MOTORS Marine dealer.</p> <p>Replace fuel.</p> <p>Replace or drain water from fuel filter. Check fuel supply for water contamination. If water is present, drain fuel tank and flush with fresh fuel.</p> <p>Check Engine Management System display for service code.</p> <p>Charge or replace battery.</p> <p>Cancelled by ignition “OFF – ON”</p>
Starter won't crank engine	<ol style="list-style-type: none"> <li>1. Battery connections loose or corroded</li> <li>2. Battery is dead</li> <li>3. Starter connections loose</li> <li>4. Ignition switch</li> <li>5. Fuse blown on panel</li> <li>6. Starter auxiliary relay</li> </ol>	<p>Check for loose connections and corrosions. Clean connections and tighten.</p> <p>Check level of electrolyte and charge battery.</p> <p>Check connections and tighten. If solenoid clicks when attempting to start engine, see your STEYR MOTORS Marine dealer.</p> <p>If inoperative, see your STEYR MOTORS Marine dealer.</p> <p>Check and replace if defect.</p> <p>Check terminal connection and function of relay.</p>
Engine runs erratically	<ol style="list-style-type: none"> <li>1. Water, air and/or dirt in fuel filter</li> <li>2. Anti-siphon valve stuck</li> <li>3. Fuel pump</li> </ol>	<p>Replace filter. Inspect fuel supply line.</p> <p>Clean and inspect or replace. (Tank)</p> <p>Check operation of pump. Replace fuel pump. See your STEYR MOTORS Marine dealer.</p>

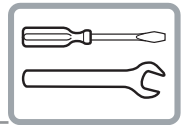

**Trouble Check Chart – Continued**

<b>SYMPTOM</b>	<b>POSSIBLE CAUSE</b>	<b>ACTION</b>
Engine vibrates	Propeller condition  Unit injector	Check for bent, broken, or damaged propeller. Check for weeds on propeller or sterndrive gearcase. Check for bent propeller shaft.  See your STEYR MOTORS Marine dealer.
Engine runs but boat makes little or no progress	Fouled propeller etc.	Check: 1. Propeller for weeds, remove as required. 2. Propeller for spun hub, repair or replace. 3. Hull for excessive marine growth, clean as required.
Performance loss	1. System error or failure  2. Boat overloaded 3. Boat trim 4. Excessive water in bilge 5. Boat hull condition  6. Improper propeller selection  7. Fuel incorrect  8. Throttle not fully open  9. Overheating    10. Air intake troubles	Check: using diagnostics for errors or limitations. Engine coolant temperature; audible and or visual alarms.  Reduce load.  Distribute boat load evenly. Adjust trim.  Drain bilge.  See your STEYR MOTORS Marine dealer.  Select proper propeller pitch and diameter.  Fill tank with correct fuel. Check fuel filter and fuel flow condition.  Check throttle command lever for full travel.  Check cooling system. Remove debris from water intake. Check belt tension. Check condition of impeller. Check for clogged heat exchanger tubing (in raw water circuit).  Check intake air filter.  Check ventilation of engine compartment.
Excessive free play in steering wheel	Steering cable loose	See your STEYR MOTORS Marine dealer.
High shift effort	1. Remote control or transom bracket shift cable  2. Remote control binding  3. Engine/drive mechanism binding	Replace and adjust. See your STEYR MOTORS Marine dealer.  See your STEYR MOTORS Marine dealer.  See your STEYR MOTORS Marine dealer.

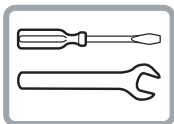

## Wiring harness

Designation	Component	Description
A5	E-Box	control unit
F1	fuse 50 A	main fuse
F2	fuse 50 A	glow plugs
F3	fuse 50 A	glow plugs
F4	fuse 5 A	permanent current modul and K27
F5	fuse 10 A	switched current for module (K27)
F6	fuse 10 A	fuel pump (K24)
F7	fuse 10 A	preheating – control circuit
G1	alternator	
G2	battery	to be provided by customer
J1	plug 23-pole	connection engine cable – instrument cable
K24	relay	fuel pump
K26-1	relay	preheating – control circuit
K26-2	relay	preheating – load circuit
K27	relay	main circuit
K28	relay	start
M1	starter	
M2	fuel pump	
R10	glow pins	
X2 (S2)	plug 2-pole	gears switch
X3 (S3)	plug 2-pole	inversion switch ( <b>only SOLAS</b> )
X5 (A5)	plug 35-pole	module
X12 (B12)	plug 3-pole	boost-pressure senso
X13 (B13)	plug 5-pole	potentiometer accelerator
X14 (B14)	plug 3-pole	rack position sensor
X15 (B15)	plug 3-pole	engine speed sensor
X16 (B16)	plug 2-pole	engine temperature senso
X17 (B17)	plug 2-pole	exhaust gas temperature senso
X18 (B18)	plug 3-pole	oil pressure sensor
X19 (B19)	plug 1-pole	oil pressure gauge (optional)
X20 (Y20)	plug 2-pole	control solenoid
X22 (B22)	without stop	trim sensor (optional)
X23	plug 6-pole	diagnosis
X26 (Y26)	plug 2-pole	disconnection blow-by ( <b>only SOLAS</b> )
Z1	splice spot	earth connection sensor
Z2	splice spot	earth connection (31) on engine
Z3	splice spot	ensor supply +5 V
Z4	splice spot	earth connection (31) on E-box plate
Z6	splice spot	shield speed sensor line

### Cable numbers/principal functions:

15000-xx	ignition – positive (from ignition switch)	31100-xx	Do not connect mass for sensors with battery negative!
15012-xx	+12 volt via main relay and modulator unit A5	601xx-01	Sensor signal to modulator unit A5 and/ or instruments.
15100-xx	+5 volt supply voltage for sensors	606xx-01	Exit from modulator unit A5 to display system (tachometer, temperature display, ...)
30000-xx	battery-positive (not secured)		
30012-xx	battery-positive (secured)		
31000-xx	battery negative (GND)		



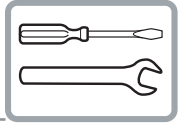

2179349\_0-03-100222

**WIRING DIAGRAM/MARINE BASE – 4/6 CYLINDER – 12 V**



**STEYRMOTORS**  
INNOVATION WITH LIGHTNESS

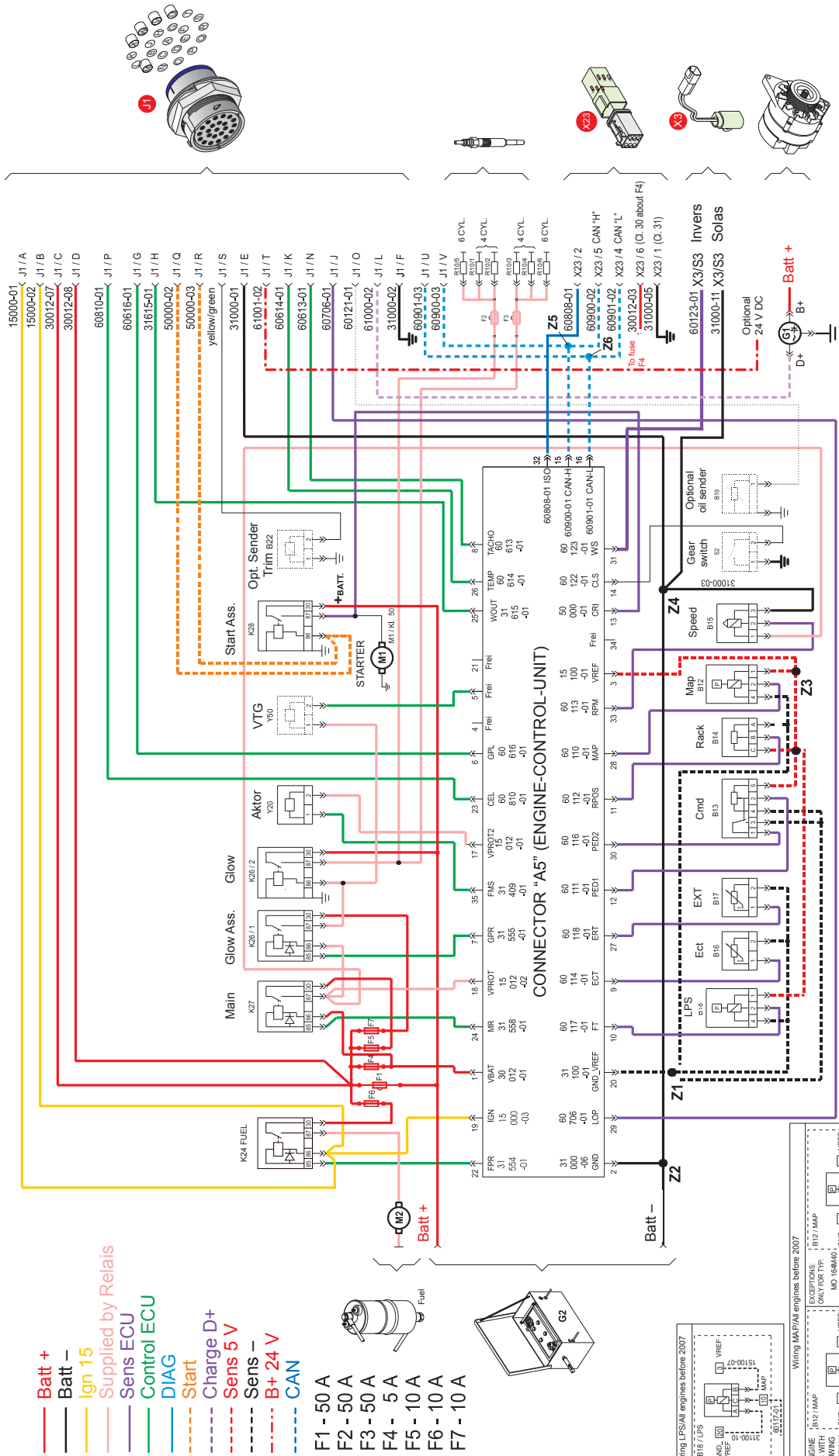

- Batt +
- Batt -
- Ign 15
- Supplied by Relais
- Sens ECU
- Control ECU
- DIAG
- - - Start
- - - Charge D+
- - - Sens 5 V
- - - Sens -
- - - B+ 24 V
- - - CAN

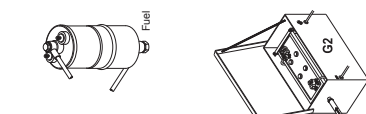

- F1 - 50 A
- F2 - 50 A
- F3 - 50 A
- F4 - 5 A
- F5 - 10 A
- F6 - 10 A
- F7 - 10 A

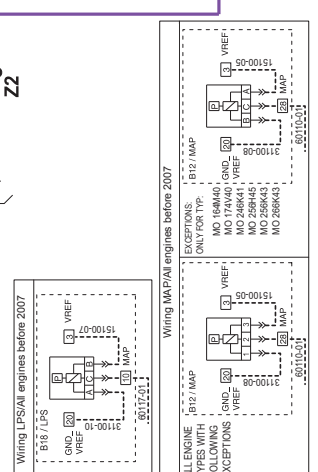

www.steyr-motors.com

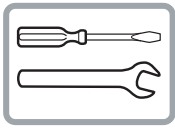

**WIRING DIAGRAM/MARINE – 4/6 CYLINDER – 2-POLE – 12 V (OPTION)**

- Batt +
- Batt -
- Ign 15
- Supplied by Relais
- Sens ECU
- Control ECU
- DIAG
- Start
- Charge D+
- - - Sens 5 V
- - - Sens -
- - - B+ 24 V
- - - CAN

- F1 - 50 A
- F2 - 50 A
- F3 - 50 A
- F4 - 5 A
- F5 - 10 A
- F6 - 10 A
- F7 - 10 A

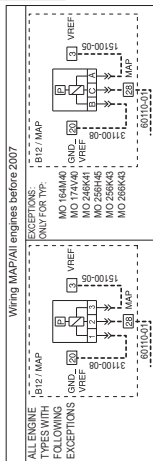
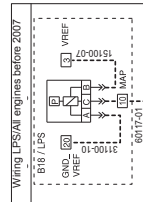
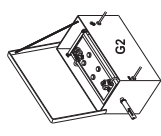
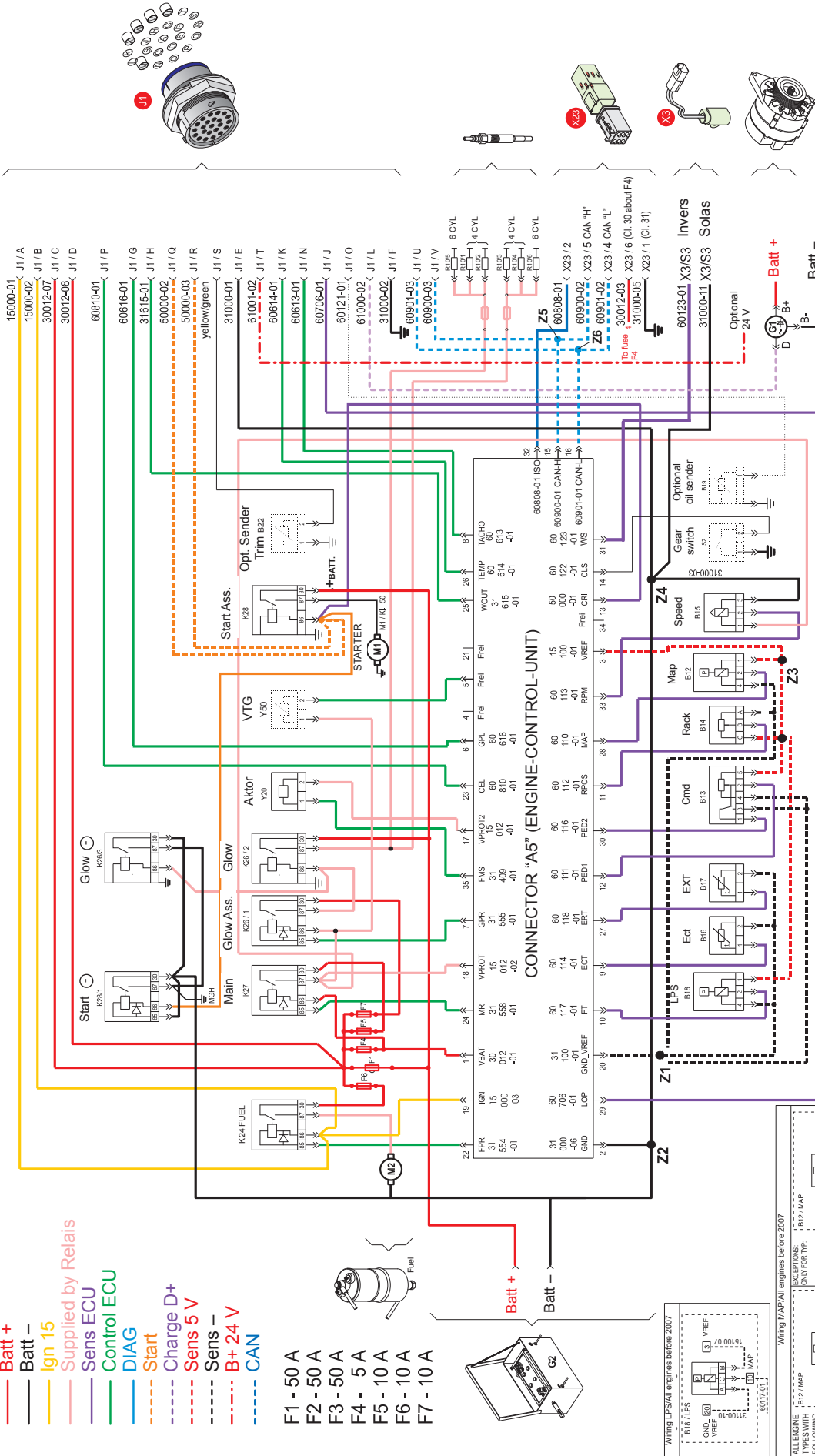

www.steyr-motors.com

2179350\_0-03-100222

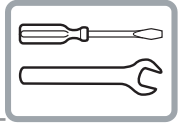

**STEYRMOTORS**  
INNOVATION WITH LIGHTNESS

**WIRING DIAGRAM/MARINE – 4/6 CYLINDER – 24 V (OPTION)**

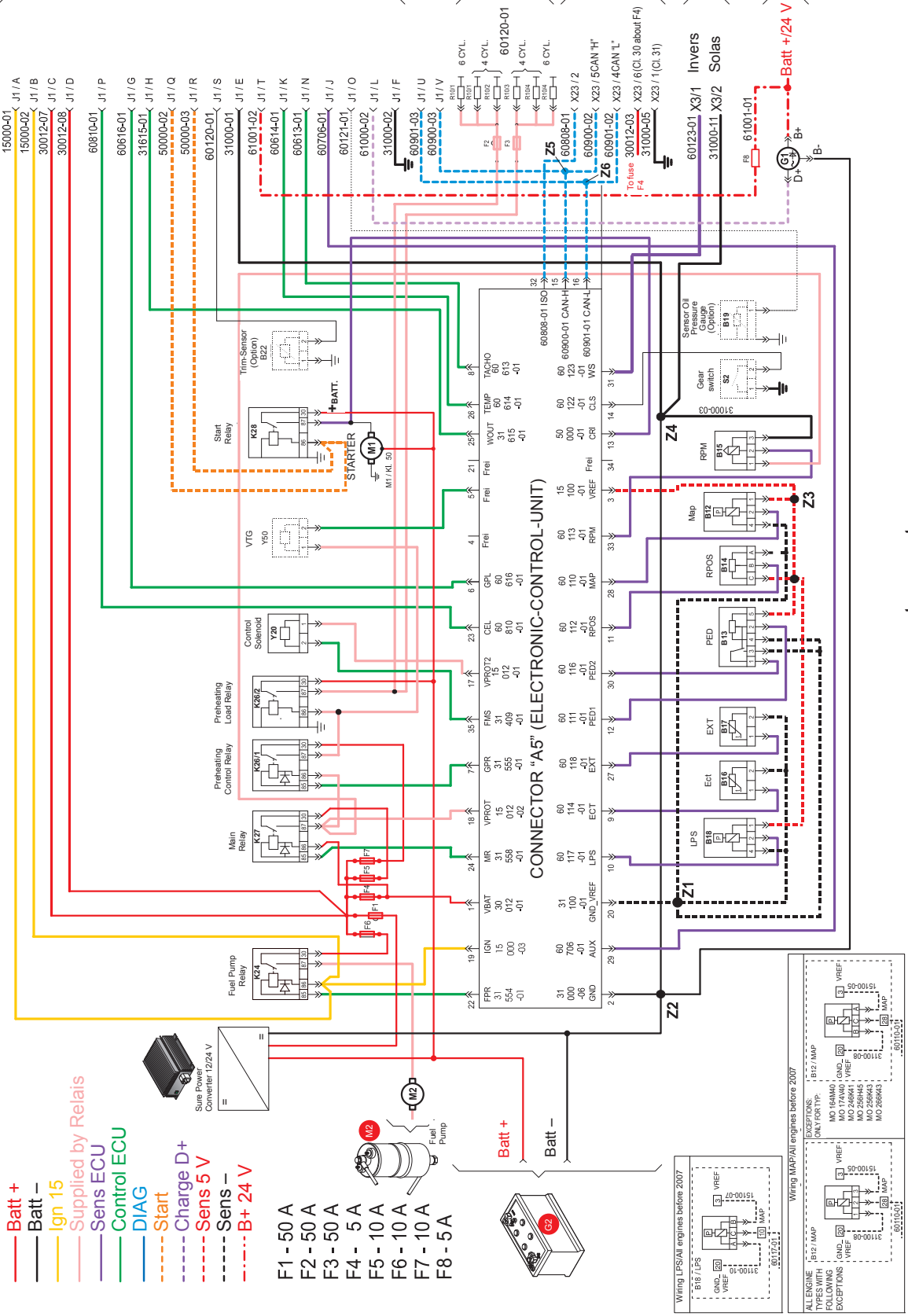

2180808-0\_00\_110329

www.steyr-motors.com

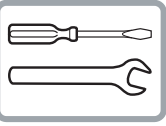

**STEYRMOTORS**  
INNOVATION WITH LIGHTNESS

**STEYRMOTORS**  
INNOVATION WITH LIGHTNESS



2179729\_D-01-100222

**WIRING DIAGRAM/MARINE – 4/6 CYLINDER – 2-POLE – 24 V – COMPLETE SYSTEM**

- Batt +
- Batt -
- Ign 15
- Supplied by Relays
- Sens ECU
- Control ECU
- DIAG
- Start
- - - Charge D+
- - - Sens 5 V
- - - Sens -
- - - B+ 24 V
- - - CAN

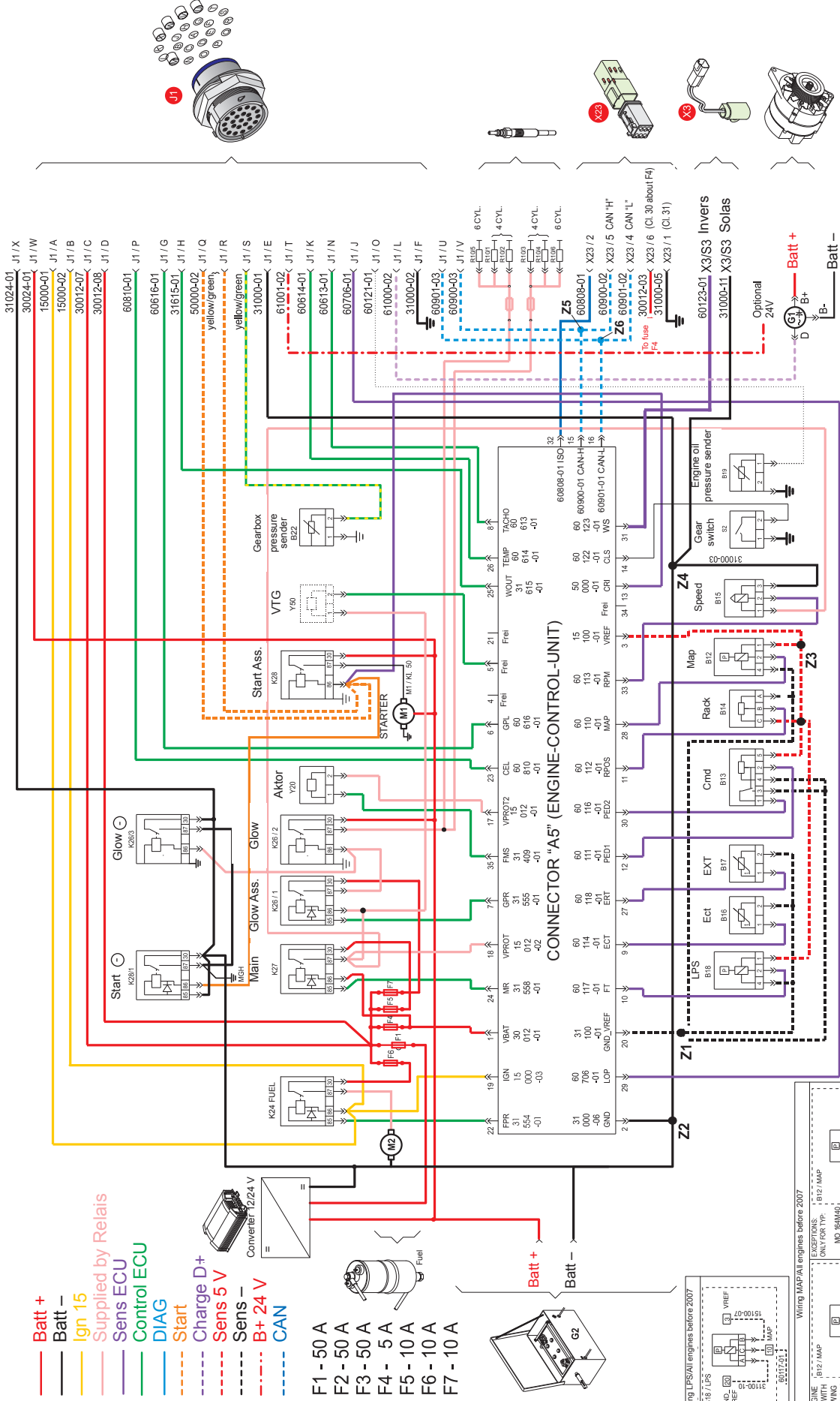

- F1 - 50 A
- F2 - 50 A
- F3 - 50 A
- F4 - 5 A
- F5 - 10 A
- F6 - 10 A
- F7 - 10 A

www.steyr-motors.com

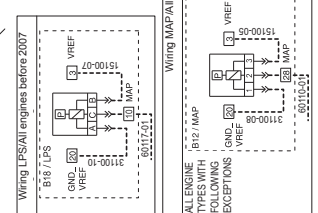

84

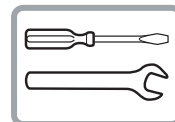

**Description – Wiring harness instrument panels 4/6 cyl. marine engines (current version)**

Designation	Component	Description
F9	fuse 10 A	
J1	23-pin plug	connection engine cable – instrument cable
S1	switch	ignition (red)
S2	switch	start (green)
S3	switch	emergency cut off (orange)
S7	switch	key switch constant revolution (optional)
L1	lamp	charge control
L2	lamp	cel – check engine lamp
L3	lamp	oil pressure/preheating control
P1	gauge	engine coolant temperature
P2	gauge	oil pressure (optional)
P3	gauge	tachometer with running-time meter
H22	warning horn	
E10	lighting	engine coolant temperature gauge
E11	lighting	oil pressure gauge (optional)
E12	lighting	tachometer gauge
X8	1-pin plug	connector illumination switch
X24	8-pin plug	connector STEYR MOTORS – display
Z1	splice	battery +
Z2	splice	battery –
Z3	splice	ignition (+)
Z4	splice	key switch constant revolution
24 V	interm. cable	charge indicator

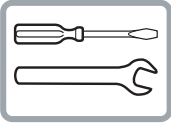

**WIRING DIAGRAM/INSTRUMENT CAN PANEL – 4/6 CYLINDER – 12 V**

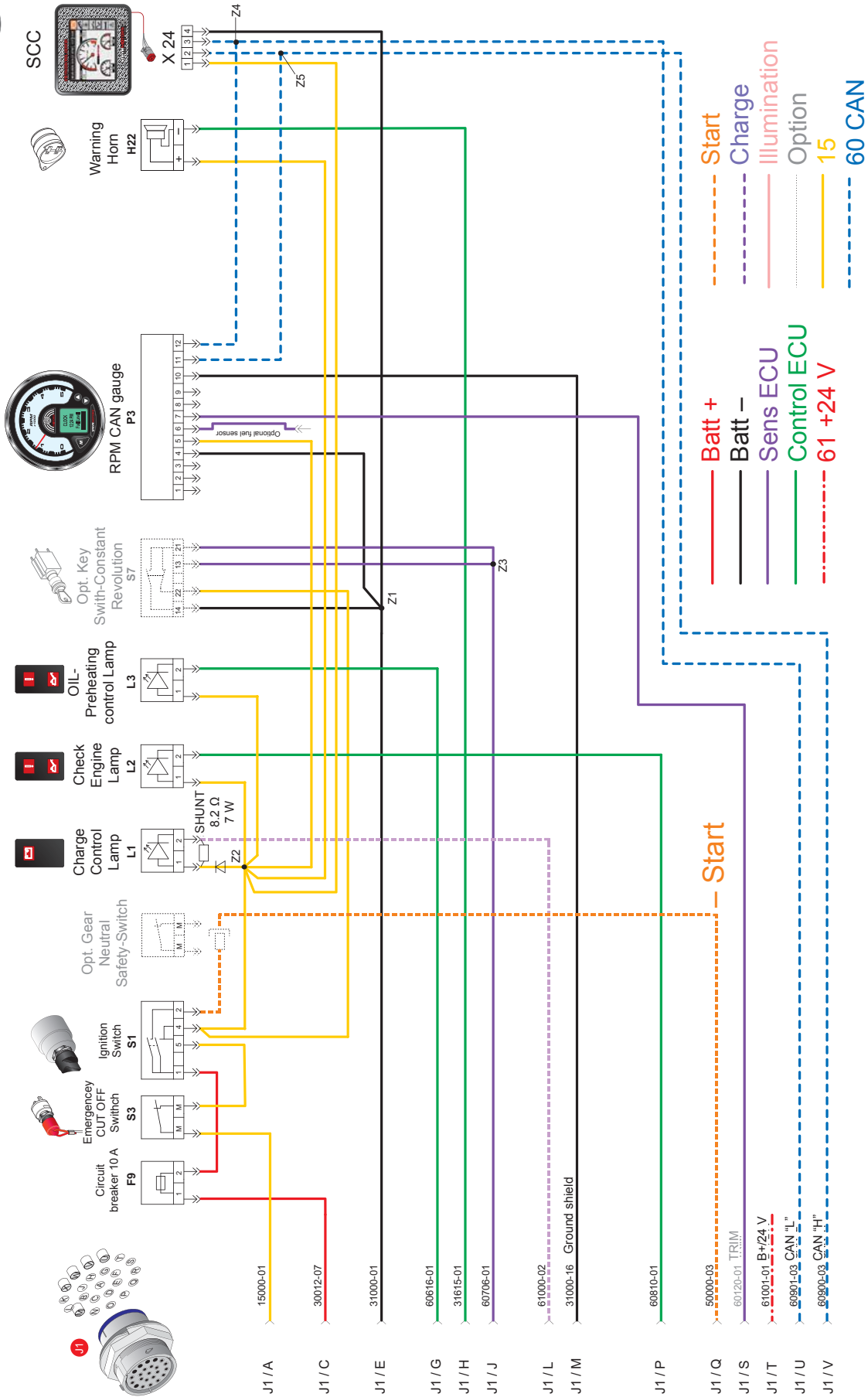

www.steyr-motors.com

2179756-D\_00\_090213

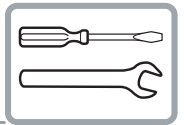

**WIRING DIAGRAM/INSTRUMENT CAN PANEL – 4/6 CYLINDER – 24 V (OPTION)**

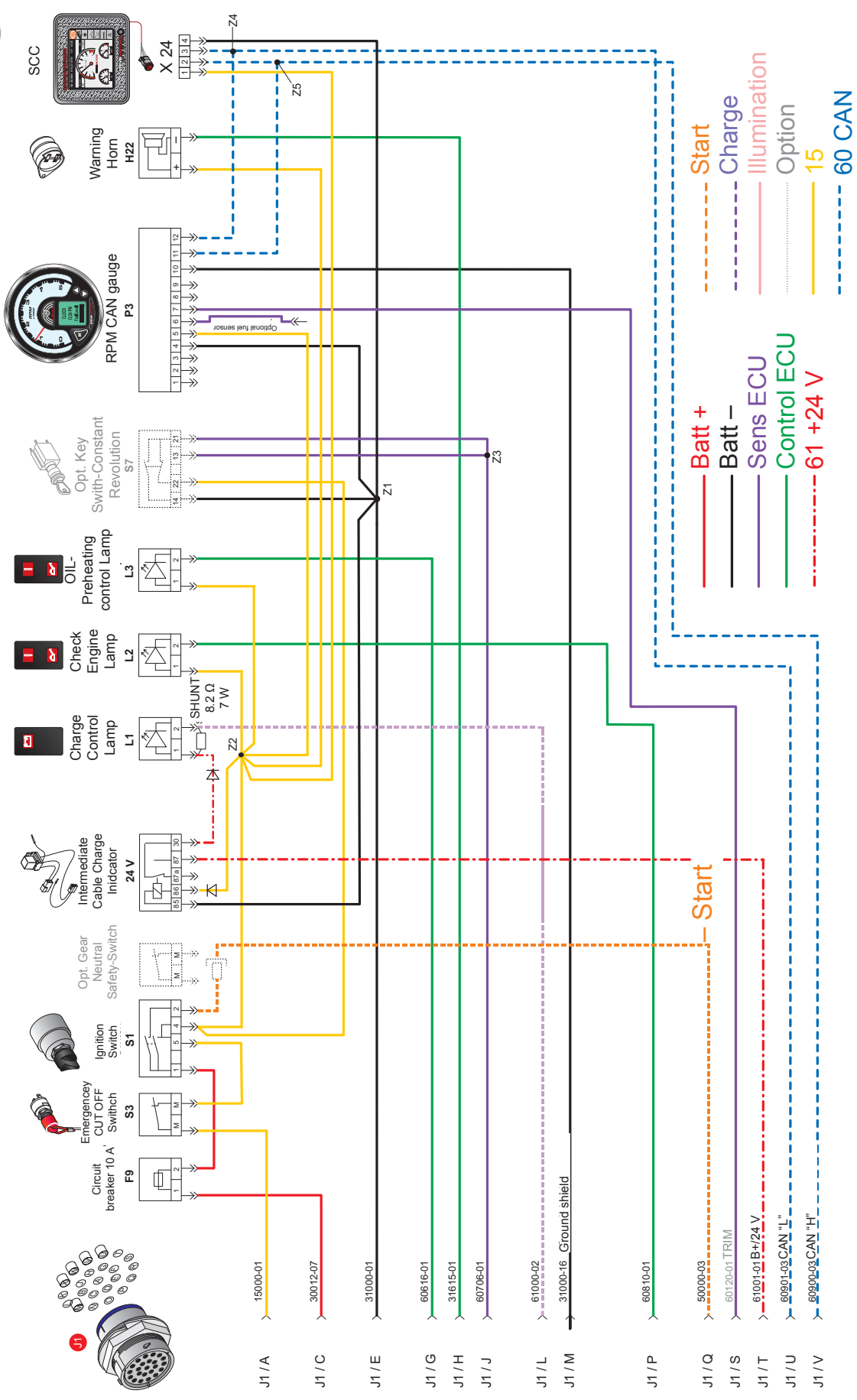

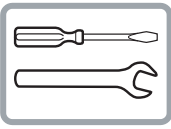

**WIRING DIAGRAM/INSTRUMENT CAN PANEL – 4/6 CYL. – Solas – 12 V (OPTION)**

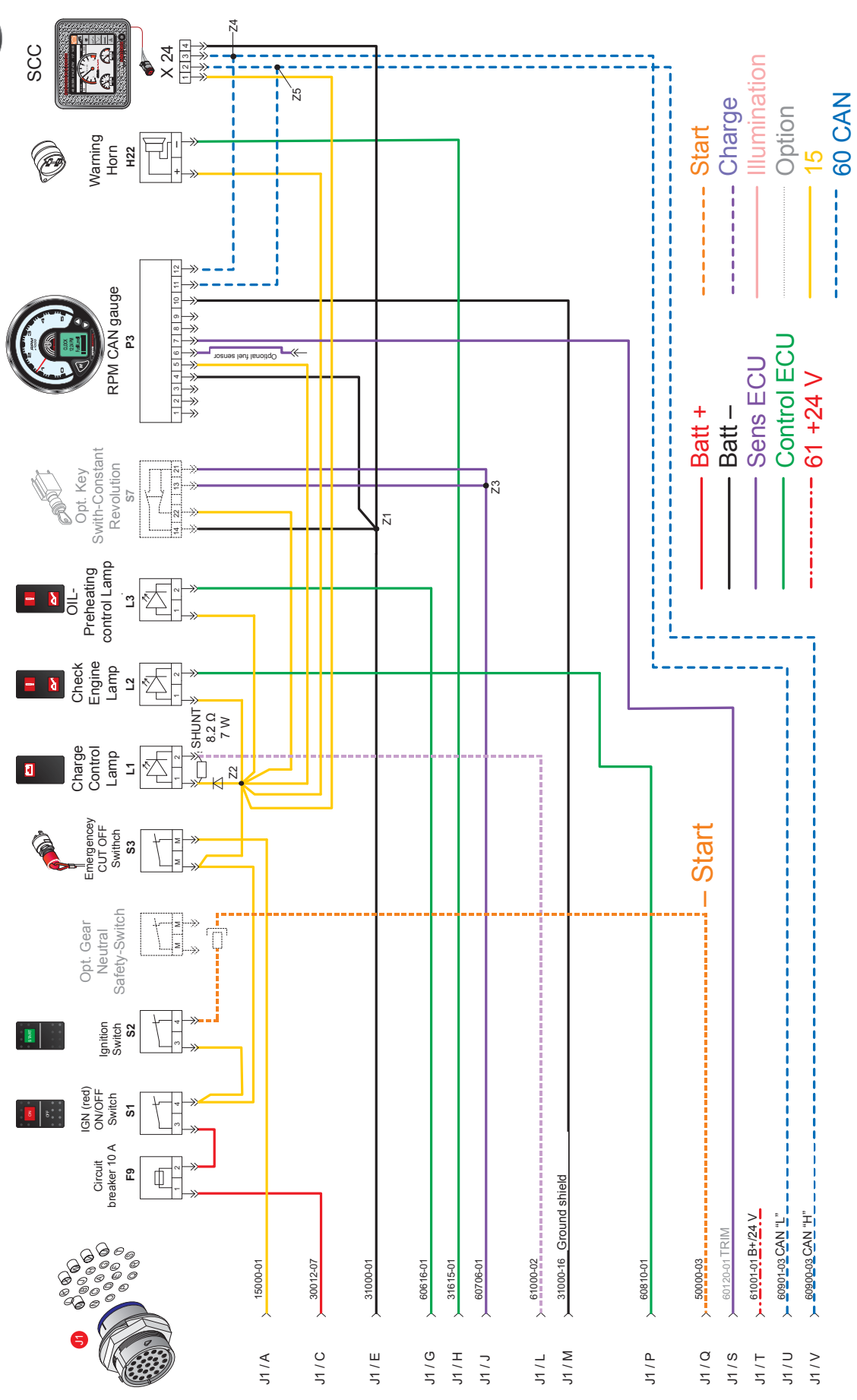

2179765-D\_01\_091110

www.steyr-motors.com



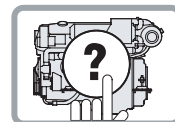

## DEALER'S RESPONSIBILITIES

Check motor oil level .....	91
Refill motor oil .....	91
Oil level for Power Steering .....	91
Oil level for Transmission .....	91
Check coolant (closed cooling circuit) .....	92
Drain the raw water circuit of the engine .....	92
Check raw water (open circuit with pump) .....	92
Cooling System Anodes .....	93
Anti-Corrosion Anodes .....	93
Maintainance Poly-V-belt resp. Serpentine Belt .....	94
Engine alignment .....	94
Air Filter .....	94
Adjustment of belts .....	95
Measuring device VR00515/0 for toothed- and V-belt .....	95
Alternator belt .....	95
Servopump belt (if so) .....	95
Belt for raw water pump .....	95
Propeller Selection .....	97
STEYR MOTORS – Dealer – Check-List .....	98
Commissioning REPORT .....	100
Preparations for Off-Season Storage .....	102
Start-up after Storage .....	102
ENGINE LOG .....	103

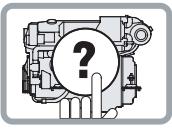

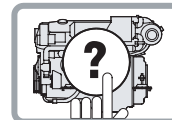

## Check motor oil level

**ATTENTION:** Check with cooled down engine only, or after a shut down period of app. 3 to 5 min.



- 19** Then remove oil dipstick (**19/A**), clean it and insert again into oil dipstick tube (**19/A**), then remove again and check oil level on marker.

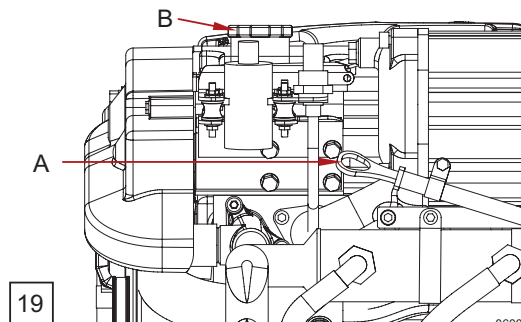

## Refill motor oil

Remove motor oil filler cap (**19/B**) and add **STEYR MOTORS TURBO DIESEL ENGINE OIL 5 W-50/10 W-40** or an equivalent marked **ACEA B4-02/E7, E4, E5** or with **API Code CF** up to specified **maximum marker** on oil dipstick.

**ATTENTION:** Motor oil must not exceed maximum marker. An overfilling results in high operating temperatures, foaming (air in oil), loss in efficiency and reduced engine life.



Put on the motor oil filler cap.

**NOTE:** Remove possible oil contaminations. The use motor oil with other quality than specified warranty can expire.

**19**



**20**

## Oil level for Power Steering

- 21** Whenever you check motor oil level, also check oil level of power steering. If required, add automatic transmission oil (available with your STEYR MOTORS Marine dealer). Other approved oils, such as GM Servo or Dexron II, may also be used. Do not overfill pump reservoir.

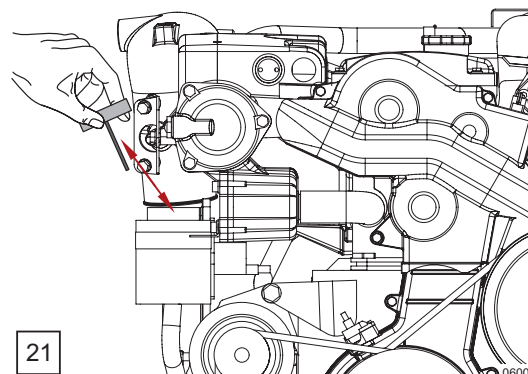

**21**

## Oil level for Transmission

- 22** Whenever you check motor oil level, also check oil level of transmission. If required, add automatic transmission oil (available with your STEYR MOTORS Marine dealer). Other approved oils, such as GM Servo or Dexron II, may also be used. Do not overfill transmission.

**NOTE:** Consider specifications of respective transmission manufacturer

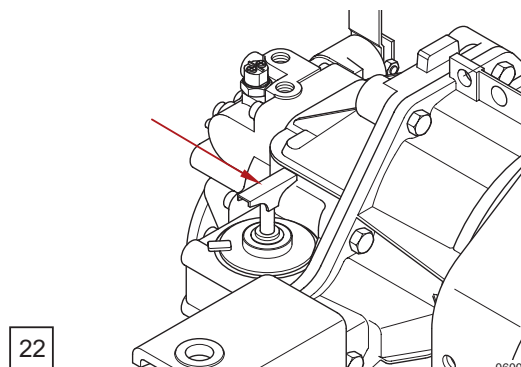

**22**

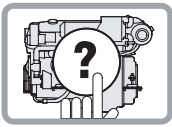

## Check coolant (closed cooling circuit)

**ATTENTION:** With hot engine, the closed cooling circuit is under pressure. Do not try to open the radiator cap or the drain plugs when engine is hot. This may cause severe injuries by hot coolant. As soon as the engine has cooled down, the cap may be opened.



- 23** Remove radiator cap (**23/A**). Coolant level should reach the "MAX" marking (**23/B**) in the expansion tank.

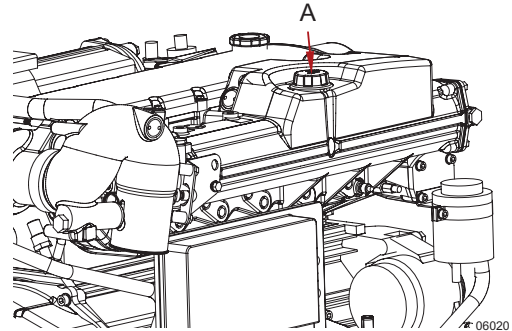

**ATTENTION:** Only add STEYR MOTORS engine coolant.



**NOTE:** When not using the original STEYR MOTORS coolant, severe damage to the cooling system of your engine may occur.

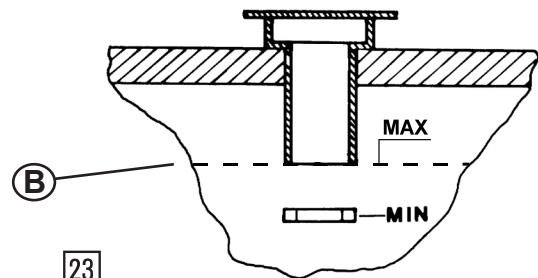

## Drain the raw water circuit of the engine

**ATTENTION:** Not draining the raw water circuit in time before the winter season and/or daily when running the engine during the winter season, may lead to freeze damage on the engine.



- 24** Remove drain plug (**24/A**). Engine empties itself via exhaust system.

**NOTE:** Drain plug (24/A) is not available for all types, in that case remove the hose.

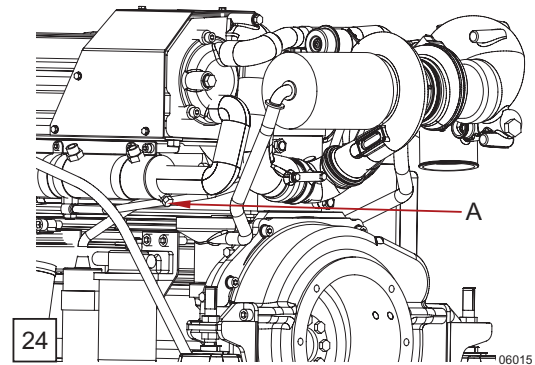

- 25** Loosen 2 hose clamps (**25/A**) and remove raw water hoses, quickly start the engine so that raw water pump empties itself.

**NOTE:** As to procedure for draining the remaining equipment on your boat, see your STEYR MOTORS Marine dealer.

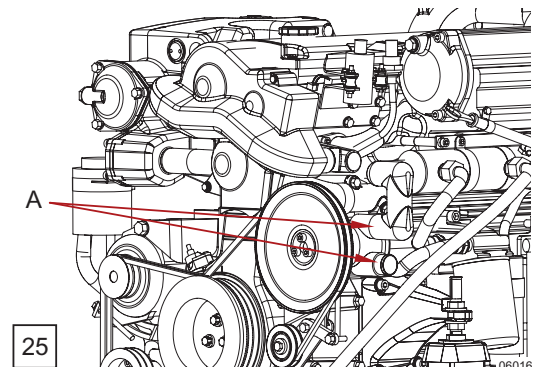

## Check raw water (open circuit with pump)

Filling is done automatically via raw water pump after having started the engine.

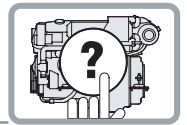

## Cooling System Anodes

26 27

### FOR ALL 4 CYL. MARINE ENGINES

28 29

### FOR ALL 6 CYL. MARINE ENGINES

There are 4 sacrificial zinc anodes in the raw water cooling system normally, although if an exhaust high riser is used there is one extra fit in it. Which are installed as per ill. 26 and 27.

Remove and inspect anodes for galvanic erosion according to the maintenance schedule.

Replace anode when material loss is 50 – 75 %.

## Anti-Corrosion Anodes

If additional electronic equipment is installed, each should have an individual anode or grounding device and all grounding devices must be interconnected. Follow recommendations of manufacturers of equipment.

**NOTE:** Inspect anodes every 30 days, or more frequently if used in extremely salty water. Anode is to be replaced according to the maintenance schedule.

Boats that connect to an AC power source (shore power) require protection against increased potential of galvanic and “spray current” corrosion. For protection, a galvanic isolator can be installed in series with the grounding (green) wire in the shore power cable between the boat and the shore power outlet on the dock. The isolator blocks direct current (DC) flow, but permits the passage of alternating current (AC) thus providing a path for ground fault currents.

**NOTE:** If a boat is connected to an AC power source (shore power), and it is not equipped with a galvanic isolator, the zinc anti-corrosion anodes may be unable to handle the added corrosion potential.

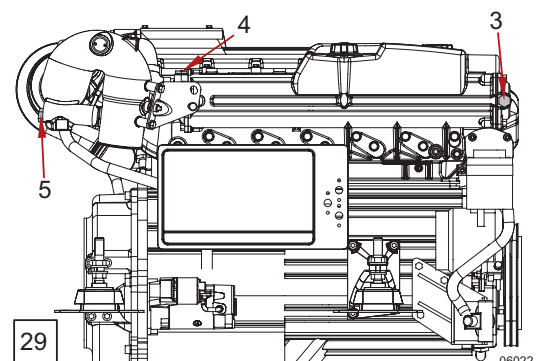
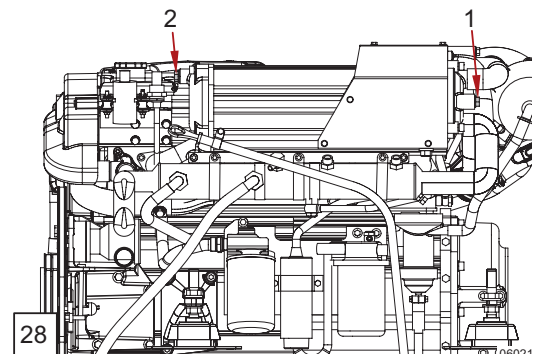
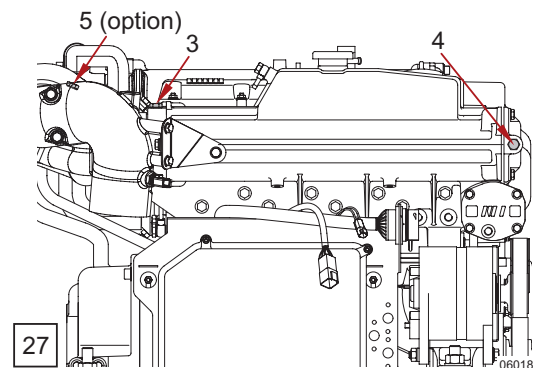
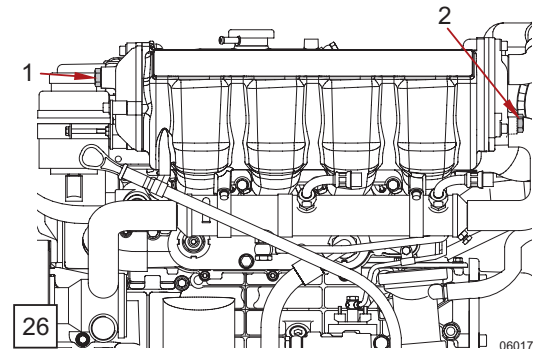

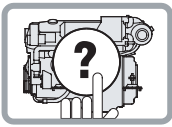

### Air Filter

All **STEYR MOTORS Marine Engine** models are equipped with an air filter at the turbocharger inlet; as to specifications, see **Specifications and Maintenance**.

- 31** Loosen clamp to exchange air filter. Remove air filter. Place clamp on filter neck and mount air filter onto flange. Tighten clamp. (3 Nm)

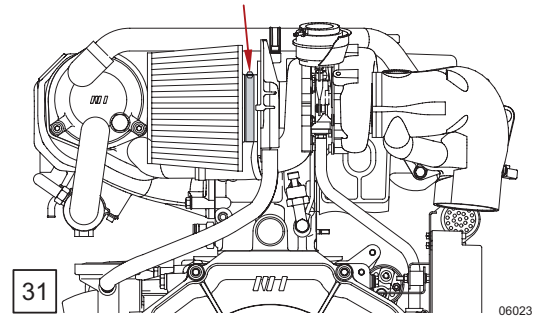

### Maintainance Poly – V – belt resp. Serpentine Belt

#### FOR 4 CYL. MARINE ENGINES

- 32** Occassionally check components for excessive wear and/or clearance on tension bearing.

**NOTE\*):** It is recommended to spray frequently some corrosion inhibiting spray into the spring housing of the belt tensioner.

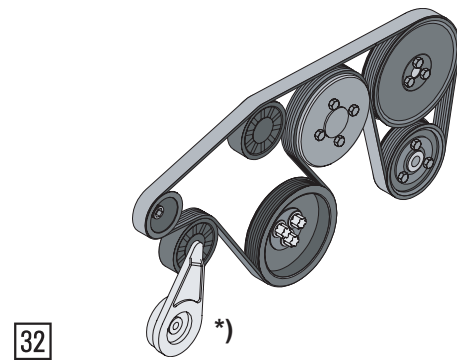

#### FOR 6 CYL. MARINE ENGINES

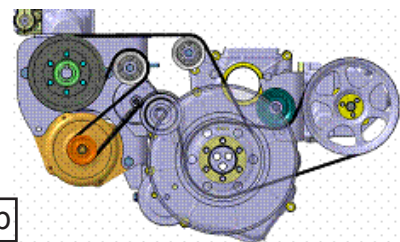
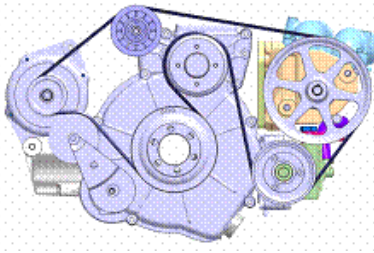

- 32a** and **32b** Occassionally check components for excessive wear and/or clearance on tension bearing.

**NOTE:** It is recommended to spray frequently some corrosion inhibiting spray into the spring housing of the belt tensioner

### Engine alignment

Engine alignment requires special tools. The output coupler must be disengaged from the take-off shaft. This should be rechecked during off-season storage preparations. Because of the special tools required, engine alignment is to be performed by a STEYR MOTORS Marine dealer.

**NOTE:** Failure to check the engine alignment could result in premature failure of engine coupler or universal joints.

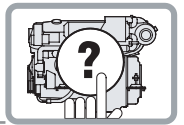

## Adjustment of belts

### FOR 6 CYL. MARINE ENGINES WITH V-BELT

#### Measuring device VR00515/0 for toothed- and V-belt

- 33** With engine stopped, tension of the belt should be so that it yields for **6 – 13 mm (350 ± 50 N)** when pressing your finger on marked spots **(A)** and **(B)**. If the belt is too slack, it may slip through which results in higher wear and bad efficiency of generator or pump. Belt tension is to be checked after first 10 operating hours and then every 50 operating hours.

**NOTE:** Alternator belts and servo pump belts are special Marine belts. **DO NOT** replace by traditional V-belts.

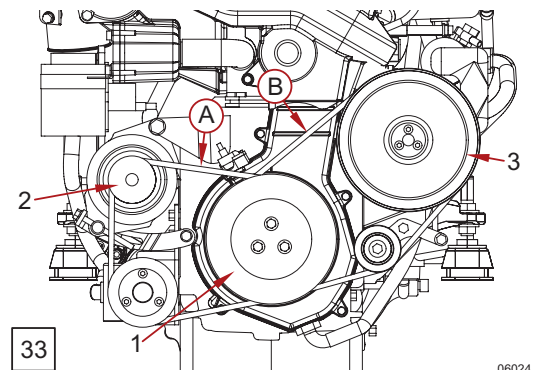

06024

#### Alternator belt

- 33** Check tension of alternator belt on spot **(A)** in the center between crankshaft belt pulley **(1)** and alternator belt pulley **(2)**.
- 34** **Retighten the belt:** – Loosen the alternator holding-down bolts **(34/C)** and **(34/D)**. Turn the clamping bolt **(E)** clockwise, (turn away alternator from engine) and increase belt tension **(350 ± 50 N)**. Tighten screws **(C)** and **(D)**. Check belt tension.

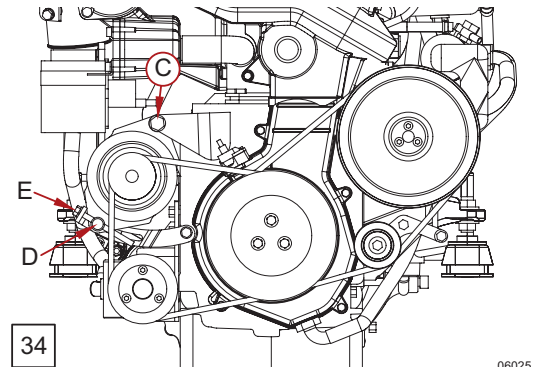

06025

#### Servopump belt (if so)

**NOTE:** Servopump is jointly driven with alternator, tension belt via alternator.

#### Belt for raw water pump

- 33** Check tension of belt for raw water pump halfway **(B)** between crankshaft belt pulley **(1)** and belt pulley on raw water pump **(3)**.

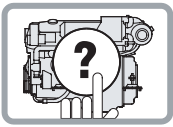

## FOR 6 CYL. MARINE ENGINES WITH V-BELT

35 36

**To tension the belt:** Loosen hexagon screw **(35/F)**. Turn the clamping bolt **(36/G)** clockwise in order to increase the belt tension to **300 ± 50 Nm**. Tighten hexagon screw **(35/F)** with a Torque of **23 Nm ± 2** to secure idle pulley bracket. Check belt tension.

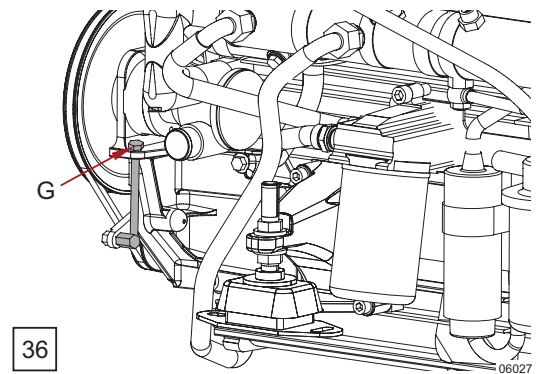
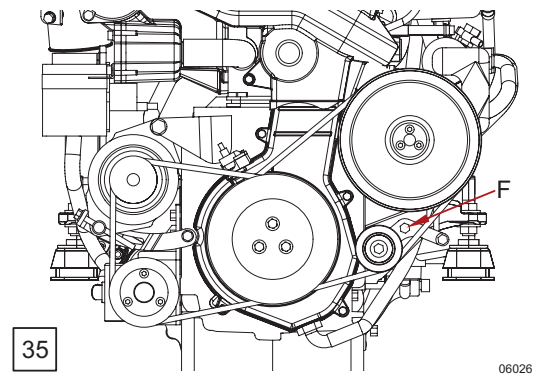



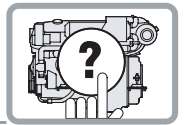

## Propeller Selection

**37** Your STEYR MOTORS Marine dealer has chosen a propeller designed to deliver top performance and economy under most conditions. To obtain the maximum percentage of available output (A), the engine RPM at **Full Throttle** should be in the specified **Full Load Speed Range** (←B→). As to specifications, see **Technical Data and Maintenance**.

If the engine's full throttle RPM with normal load is below the specified range, use a propeller with less pitch to increase the RPM. Should the engine's full throttle RPM exceed the specified range, the engine RPM and output is limited by the governor. Use a propeller of higher pitch to achieve a RPM reduction in the specified range (←B→).

**NOTE:** Engine damage can result from incorrect propeller selection if

- The engine RPM **does not attain** the specified “**Full Load Speed Range**”.  
The engine thus runs in RPM range (←C→).

Therefore, use a propeller with **a lower pitch**.

- The engine RPM exceeds the specified “**Full Load Speed Range**”.  
Engine speed is therefore above the admissible range (←D→).

Therefore, use a propeller with **a higher pitch**.

engine model		Full Load Speed Range “B” rated rpm (range of tolerance)
4 cylinder	MO54NA33	3,300 rpm (+0 rpm/−200 rpm)
	MO84K32	3,200 rpm (+0 rpm/−200 rpm)
	MO94K33	3,300 rpm (+0 rpm/−200 rpm)
	MO114K33	3,300 rpm (+0 rpm/−200 rpm)
	MO144V38	3,800 rpm (+0 rpm/−300 rpm)
	MO144M38	3,800 rpm (+0 rpm/−300 rpm)
	MO164M40	4,000 rpm (+0 rpm/−300 rpm)
	MO174V40	4,000 rpm (+0 rpm/−300 rpm)
6 cylinder	MO126K25	2,500 rpm (+0 rpm/−200 rpm)
	MO126M28	2,800 rpm (+0 rpm/−200 rpm)
	MO156K25	2,500 rpm (+0 rpm/−200 rpm)
	MO166M28	2,800 rpm (+0 rpm/−200 rpm)
	MO196K35	3,500 rpm (+0 rpm/−200 rpm)
	MO236K42	4,200 rpm (+0 rpm/−300 rpm)
	MO236K43	4,300 rpm (+0 rpm/−300 rpm)
	MO256K43	4,300 rpm (+0 rpm/−300 rpm)
	MO256H45	4,500 rpm (+0 rpm/−300 rpm)
	MO286H43	4,300 rpm (+0 rpm/−300 rpm)
	MO306H43WJ	4,300 rpm (+0 rpm/−300 rpm)

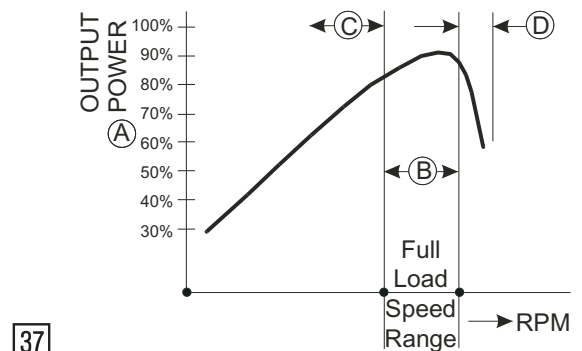

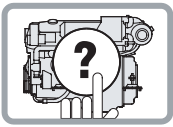

## STEYR MOTORS – Dealer – Check-List

**NOTE:** If STEYR MOTORS HYBRID SYSTEM is in use, check below mentioned points but also START UP OF HYBRID SYSTEM (see HYBRID INSTALLATION MANUAL P/N Z001044-0/ chapter 5) before ignition is turned on or engine is started!

1. Remove carton from palette and check the separately packed components are complete and undamaged.
2. Visual inspection of engine for transit damage and finish.
3. Check coolant and oil level. If required add operational fluids as specified in Operation, Maintenance & Warranty Manual and Service Manual.
4. Inform customer about important guidelines in the Installation Manuals and instruct him as to safety regulations.
5. Inform customer about break-in procedure in the Operation, Maintenance & Warranty Manual.
6. Advise customer what to do when the engine's self-diagnostic management system reduces the power. See Electronic Engine Control Unit (ECU) in section Start-up and Operation of Operation, Maintenance & Warranty Manual.
7. Check tightness of all cooling water hose clamps.
8. Check fuel hoses for correct size and safe routing to and from engine.
9. Check battery units for correct polarity and battery for correct capacity.
10. Check all electrical connections (engine harness, main connector, accessories, instrument panel)
11. Check level of all operational fluids:
  - Motor oil
  - Coolant
  - Power steering fluid
  - Drive or gear
  - Reservoir of trim pump
12. Fill fuel tank for engine test run.
13. Check function of displays on instrument panel.
14. Check function of bilge pump and blower.
15. Check fuel system for free flow and leaks.
16. Check function of trim installation.
17. Check function of anchor light, navigation lights and instrument panel lights.
18. Install drain plug of bilge.

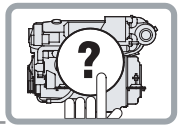

19. Steering – Lubricate
20. Check condition and tension of all drive belts.
21. Check all engine mount screws for tight seat.
22. Check for any leaks, deficiencies, signs of wrong use etc.
23. Check function of all warning devices installed.
24. Read out memorized service codes and make necessary corrective actions.
25. Start engine and check for normal instrument display and normal operating noise.
26. Obtain propeller load absorption.
27. Check installation and fill in commissioning report (Installation Manual P/N Z001007-0, chapter 9 Appendix).
28. Grease raw water pump impeller at BUKH-STEYR MOTORS SOLAS engine with original grease of P/N Z011753/2.
29. Carry out Start-Idle-Test and check engine operation. Check behavior of the boat when engine is in idle gear. If there are unpleasant vibrations, adjust the engine speed to a vibration-free operation (see Service Manual)
30. Check correct function of gearshift.
31. Stop engine and check again the levels of all operational fluids during test run a certain loss operation fluids may occur.

.....  
(Mechanic's Signature)

.....  
(Dealer's Signature)

DEALER: .....

ADDRESS AND DATE: .....

ENGINE TYPE/SERIAL NUMBER: .....

ENGINE RUNNING HOURS: .....

SIGNATURE: .....

**A copy of the “installation and pre-delivery inspection log” is to be sent to STEYR MOTORS GmbH, After Sales Service!**

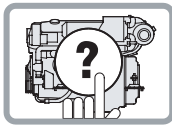

<b>Engine-serial number:</b>	<b>Engine-model:</b>
*) Hybrid-serial number:	
Boat Owner:	
Company/Name:	
Address/Phone:	
Dealer:	
Company:	
Address/Phone:	
Type of boat:	Dimension of propellers:
Model No.:	Special Equipment from STEYR MOTORS (SCC, IFG, Cabin Heating etc.):
Boat length:           m	
Boat weight:           kg	
Driving system:	*) Hybrid-Battery specification:
Gear reduction:	
Extended Storage Preservation Procedure (acc. SERVICE Manual/GENERAL/D3)	
Date of Preservation: # 1                   # 2	
<b><u>ENGINE-CHECK POINTS:</u></b>	
Installation checked according to the installation guide. Following points are in compliance:	
<input type="checkbox"/> 1 <input type="checkbox"/> 2 <input type="checkbox"/> 3 <input type="checkbox"/> 4 <input type="checkbox"/> 5 <input type="checkbox"/> 6 <input type="checkbox"/> 7 <input type="checkbox"/> 8 <input type="checkbox"/> 9 <input type="checkbox"/> 10	
NOTES:	
*) <b>HYBRID</b>	
<input type="checkbox"/> ELECTRICAL CONNECTIONS according schematic "CONNECTION SCHEMATIC-HYBRID" <small>(see Hybrid Installation Manual-schematic with art.nr. 2180526-0)</small> Notes (e.g.: wiring extensions etc.):	
<input type="checkbox"/> SYSTEM GROUNDS connected (see Hybrid Installation Manual-schematic with art.nr. 2180526-0)	
<input type="checkbox"/> PROTECTION COVERS mounted on: <ul style="list-style-type: none"> <li><input type="checkbox"/> HCU (U, V, W and B+, B-) <input type="checkbox"/> Generator (U, V, W) <input type="checkbox"/> Hybrid battery (+/-)</li> </ul>	
<input type="checkbox"/> END POSITON / FREE MOVEMENT of Coupling Actuator (D-Mode, E-Mode) ensured	
<input type="checkbox"/> MAIN SWITCH capacity (between Hybrid battery+ and HCU+):           Amp (min. 400 Amp)	
<input type="checkbox"/> CONSUMERS mounted to Hybrid battery (only to 48 V, max. 100 Amp):	
<input type="checkbox"/> Hybrid-Cooling: <input type="checkbox"/> Raw water cooling <input type="checkbox"/> Dual circuit cooling <input type="checkbox"/> Keel cooling	

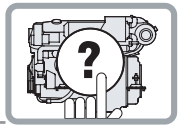

**BEFORE MEASURING DATA:**

Correct level of operating fluids (motor oil, gear oil, hydraulic oil, cooling agent) confirmed  yes  
 Leakage (oil, fuel, coolant) checked  ok if not detail:

**\*) HYBRID**

- full filled STEYR MOTORS Dealer Check List (find in Hybrid Operation, Maintenance and Warranty Manual) and send signed document to STEYR MOTORS GENERAL
- Max. Voltage supply from Hybrid-battery bank to HCU(≤57 V): V

**MEASURING DATA:**

Max. boat speed:	knots	Fuel flow amount on return-line in idle:	l/min
Max. engine-rpm by WOT (CMD=5)	rpm	Motor oil pressure (SMO-EDT):	bar
Idle speed:	rpm	Engine coolant temp. (SMO-EDT):	°C
Temperature engine compartment:	°C	Exhaust raw water temp. (SMO-EDT):	°C
Exhaust backpressure:	mbar	Boost-pressure at max. rpm (SMO-EDT):	mbar
Active engine warnings:	<input type="checkbox"/> YES <input type="checkbox"/> NO	if YES which:	
Instruments adjusted:	<input type="checkbox"/> YES		

LOG FILE (Idle – Full Load – Idle) name:

**\*) HYBRID**

Max. boat speed in E-Mode: knots  
 – with Speed Mode:  low  mid1  mid2  high  
 – max. engine rpm achieved in E-Mode: rpm

D-Mode status on SCC E-Mode ready-red, D-Mode ready-green, HCU-Mode ready-green, GENERATOR  YES  
 (see SCC User Manual Z001071-0; chapter Hybrid menu)  
 NOTES:

E-Mode status on SCC E-Mode ready-green, D-Mode ready-red, HCU-Mode ready-green, E-Drive  YES  
 (see SCC User Manual Z001071-0; chapter Hybrid menu)  
 NOTES:

Flow-rate through Hybrid cooling-system: l/min (see in Hybrid cooling schematics mentioned above)  
 Max. HCU temperature on SCC: °C (see SCC User Manual Z001071-0; chapter Hybrid menu)  
 Max. E-MOTOR temperature on SCC: °C (see SCC User Manual Z001071-0; chapter Hybrid menu)

Safeguarding instruction carried out  YES  
 Manual, warranty and operation explained  YES

Test made on: \_\_\_\_\_, by \_\_\_\_\_  
 (Name in block letters)

**Please immediately return a copy of this report and the Warranty registration card to your STEYR MOTORS GENERAL DISTRIBUTOR. Failure to do say may affect factory warranty.**

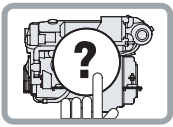

## Preparations for Off-Season Storage

An adequate preservation of the engine will contribute to an efficient and troublefree operation in the long term. Consult your **STEYR MOTORS Marine Dealer** to get professional assistance in performing a proper off season storage.

**NOTE:** If engine is stored above 1 year, advise your **STEYR MOTORS Marine Dealer** to the Extended Preservation Procedure (Service Manual P/N Z001019/0, chapter GENERAL D3).

1. Change motor oil and oil filter.
2. Change fuel filter.
3. Check air filter.
4. Check coolant (closed circuit).
5. Add fuel stabilizer to fuel.
6. Drain engine's raw water system.

**NOTE:** If the raw water is not completely removed from the engine, expensive freeze damage may be the result.

7. Drain raw water system from boat and driving system (consider manufacturer's instructions as to storage).
8. Change gear oil or lubricant.
9. Disconnect battery and store it.
10. Spray engine outside with corrosion prevention oil.
11. Ventilate engine compartment and bilge.

## Start-up after Storage

An correct start-up of the engine will contribute to an efficient and troublefree operation in the long term. Your **STEYR MOTORS Marine Dealer** will gladly be available as consultant or for an expert performance.

1. Check condition of hoses and hose clamps.
2. Clean battery terminals.

**ATTENTION:** Connect RED cable to positive terminal and then BLACK cable to negative terminal. Wrong connection of battery terminals may damage the electronic system.



3. Grease outer sides of terminals.
4. Open fuel stop valve and check all fuel lines for leakage.
5. Thoroughly check the boat and engine for slack or missing screws or nuts.
6. Pump the bilge dry and clean the engine compartment.
7. Complete the raw water system.
8. Open the raw water inlet.

**ATTENTION:** Insufficient raw water supply may damage the engine and the raw water pump.



9. Test run. Start engine. Check voltmeter, oil pressure- and water temperature gauge. (Make sure that all systems function properly.)
10. Check all parts for oil-, fuel- or water leakage.









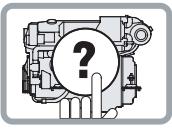



**WARRANTY**

LIMITED ENGINE WARRANTY .....	108
Engine, Gearbox, Boat Model and Hull Identification Numbers .....	115
STEYR OWNER IDENTIFICATION CARD .....	116
SERVICE NETWORK .....	117



## STEYR MOTORS – Marine Engines – LIMITED ENGINE WARRANTY

STEYR MOTORS, GmbH (“STEYR MOTORS”) warrants to the original retail purchaser of a product covered under this Warranty (“the Product”), and to any other person to whom the Product is transferred during the duration of this Warranty, that in the event of a failure of the Product occurring during the applicable warranty period resulting from a defect in materials or factory workmanship, STEYR MOTORS will, at its option, repair or replace the defective Product according to the terms and conditions set forth herein.

### Products Warranted

This Limited Warranty applies to all new marine engines manufactured by STEYR MOTORS, GmbH and sold by STEYR MOTORS or by a STEYR MOTORS approved distributor or dealer until such time as this Warranty may be subsequently updated or revised. This Warranty also applies to the following engine accessories when approved and supplied by STEYR MOTORS and when installed by STEYR MOTORS or by a STEYR MOTORS approved distributor or dealer:

- acc. To enlisted distributor as stated in STEYR MOTORS Service Network (refer to website at [www.steyr-motors.com](http://www.steyr-motors.com))

This Warranty does not apply to any component manufactured by a third party and supplied by STEYR MOTORS as part of a package. Such non-covered components include, but are not limited to, any MerCruiser Bravo Series stern drive, ZF Marine transmissions, sail drives, water jet, control lever and commander systems, etc., that may be sold together with a Steyr engine. Buyers of a package that includes a MerCruiser Bravo Series stern drive should consult the product literature accompanying the stern drive for details on the warranty provided by its manufacturer, Mercury Marine. The provided warranty registration card with the Mercury Marine/MerCruiser product needs to be returned to STEYR MOTORS for registration in their system.

### What You Must Do to Activate the Warranty

#### Owner Registration

**IMPORTANT: In order to obtain the full benefit of this Warranty, your new Steyr engines must be timely registered at the factory, latest within 3 years from the date of sales document.** The engines you have purchased have been shipped from the factory together with a Warranty Registration Card, a copy of which is included in your Operation, Maintenance and Warranty Manual. It is your responsibility to insure that the distributor or dealer from whom you purchased the engines fills out the Warranty Registration Card in its entirety and that it is immediately forwarded to STEYR MOTORS. The Registration Card must include your name and address, the product number and serial number(s), date of sale, and type of use, as well as the seller’s name, address, code number and a properly obtained commissioning report. It must also contain the selling distributor/dealer’s certification that you are the original purchaser and user of the Product.

In case of an engine doesn’t get put into operation within the first year from production, the STEYR MOTORS long-term preservation and conservation procedure must be followed and documented as described in this procedure to prove proper storage handling and re-commissioning of the product.

A copy of the Warranty Registration Card, designated “Purchaser’s Copy,” MUST be given to you immediately after the card has been completely filled out by the selling distributor/dealer. Your copy of the Warranty Registration Card should be retained together with your Owner Identification Card and kept in a safe place. In the event that you ever require warranty service, you will be required to present your copy of the Warranty Registration Card along with your Owner Identification Card so that the date of purchase and delivery may be verified and so that the Warranty Claim Form can be properly completed.

**Failure to register the Product with the factory within 60 days of the date on which you take delivery of the Product will cause the warranty period to begin running from the date on which the Product is shipped from STEYR MOTORS in Austria, rather than on the date of delivery to you.** It is to your benefit to have all Products timely registered at the factory so that you receive the maximum available coverage under the Warranty and so that STEYR MOTORS has a means of identifying and contacting you in the event of product updates or service notifications.



## Commissioning Report

Your new Steyr engines have been shipped together with a form entitled “Commissioning Report,” a copy of which is included in the installation manual that accompanies your engines. It is your responsibility to insure that this form is completed by the seller (distributor, dealer, or boat builder) at the time of installation and that it is immediately returned to STEYR MOTORS. Keep a copy of the completed form for your records, as you will be required to present it in the event you ever require warranty service. Failure to complete and immediately return the Commissioning Report to STEYR MOTORS will cause your warranty to be voided.

## Base Engine Warranty

The Base Engine Warranty covers any failure of the Product under normal use and service that occurs during the applicable period of coverage and that results from a defect in STEYR MOTORS material or factory workmanship (a “Warrantable Failure”).

### STEYR MOTORS’ Responsibilities under the Base Engine Warranty

During the applicable period of coverage under the Base Engine Warranty, and subject to all conditions, limitations and exclusions herein, STEYR MOTORS will, at its option, either repair or replace the defective Product. In the event that STEYR MOTORS elects to repair the Product, STEYR MOTORS will do the following:

- STEYR MOTORS will pay for all parts and labor reasonably required to repair the defect responsible for the Warrantable Failure.
- STEYR MOTORS will pay for all lubricating oil, antifreeze, filter elements, and other similar maintenance items replaced during a warranty repair when such items are not reusable due to a Warrantable Failure.
- STEYR MOTORS will pay for the usual and customary labor costs for engine removal and reinstallation when necessary to repair a Warrantable Failure.

Labor costs will be paid by STEYR MOTORS only for work pre-authorized by STEYR MOTORS and performed by an approved service facility during normal business hours. Labor costs will be paid in accordance with STEYR MOTORS’ published standard repair time guidelines. Parts used in warranty repairs may be new STEYR MOTORS parts, STEYR MOTORS-approved rebuilt parts, or repaired parts.

### Duration of Coverage

The duration of coverage under the Base Engine Warranty depends upon whether your engine application and use are rated for “Pleasure Duty” or for “Commercial Duty”.

- For engines rated “Pleasure Duty,” the Base Engine Warranty extends for a period of 24 months or until the engines have been operated for 1,000 hours, whichever occurs first.
- For engines rated “Commercial Duty,” the Base Engine Warranty extends for a period of 12 months or until the engines have been operated for 1,000 hours, whichever occurs first.

The period of coverage commences on the date on which the Product is delivered to the first retail purchaser, or the date on which the unit is first leased, rented or loaned, or when the Product has been operated for 30 hours, whichever occurs first.



## Extended Major Components Warranty

The Extended Major Components Warranty covers any failure under normal use and service of any of the below-listed parts or castings that occurs during the extended warranty period and that is caused by a defect in material or factory workmanship:

- Engine Monoblock Casting
- Engine Camshaft
- Engine Crankshaft
- Engine Connecting Rods
- Crankshaft Sprocket
- Camshaft Sprocket
- Engine Housing
- Flywheel Housing

## STEYR MOTORS' Responsibilities under the Extended Major Components Warranty

During the applicable period of coverage under the Extended Major Components Warranty, and subject to the conditions, limitations and exclusions herein, STEYR MOTORS will, at its option, either repair or replace the defective component. STEYR MOTORS' responsibilities in the event of a repair shall be the same as provided with respect to the Base Engine Warranty, except that the cost of labor for removal and reinstallation is not covered under the Extended Major Components Warranty.

## Duration of Coverage

The Extended Major Components Warranty extends for a period of 60 months or until the engine has been operated for 1,800 hours, whichever occurs first. As with the Base Engine Warranty, the period of coverage commences on the date on which the Product is delivered to the first retail purchaser or on the date on which the unit is first leased, rented or loaned, or when the Product has been operated for 30 hours, whichever occurs first.

---

<sup>1</sup>Bushing and bearing failures are not covered.

## Summary of Warranty Coverage

Type of Coverage	Duration (Months)	Duration (Hours/) <sup>2</sup>	Repair Costs Paid by STEYR MOTORS		
			Parts	Labor	Labor for Removal & Reinstallation
Base Engine Warranty – PLEASURE	24	1,000	Yes	Yes	Yes
Base Engine Warranty – COMMERCIAL	12	1,000	Yes	Yes	Yes
Extended Major Components Warranty	60	1,000	Yes	Yes	No

## Additional Coverage for Parts Replaced or Repaired Under Warranty

Any STEYR MOTORS product or part replaced or repaired under the Base Engine Warranty will be covered under the Base Engine Warranty for the remainder of the warranty period.

## Warranty Coverage for genuine Spare Parts

STEYR MOTORS warrants genuine spare parts for extent of 6 month from the date of sales.

## Conditions of Warranty Coverage

This Warranty is expressly conditioned upon proper application, installation, commissioning, operation, and maintenance of the Product in accordance with the specifications and guidelines set forth by STEYR MOTORS in its Operations, Maintenance and Warranty Manual and in its installation and service manuals. Proper use and operation of the Product entails, among other things, use of the Product in strict compliance with the following power ratings:

**Pleasure Duty.** This power rating is intended for use in variable load applications where full power is limited to one (1) hour out of every eight (8) hours of operation. Reduced power operations must be at or below 200 RPM of the maximum rated RPM. This rating is an ISO 3046 (ISO 8665) fuel stop power rating and is intended exclusively for pleasure/non-revenue generating applications. Engines rated “Pleasure Duty” may not be used for any commercial application without voiding the product warranty. A “commercial application” includes any work or employment-related use of the Product, or any use of the Product that creates income, even if the Product is only occasionally used for such purpose. A “commercial application” also includes charter, naval, police, and other similar applications.

**Commercial Duty.** This power rating is intended for intermittent use in variable load applications where full power is limited to two (2) hours of every eight (8) hours of operation. Reduced power operations must be at or below 400 RPM of the maximum rated RPM. This rating is an ISO 3046 fuel stop power rating and is intended for applications that operate less than 1,500 hours per year.

STEYR MOTORS’ duty of performance under this Warranty is expressly conditioned upon the purchaser’s maintenance of the following documentation and records which must be made available to STEYR MOTORS in the event that warranty service is required:

<sup>2</sup> Whichever occurs first



- You are responsible for keeping complete and accurate records of all service performed on the engines and for maintaining a log of all regularly scheduled maintenance in the Owner Service Log included in your Operations, Maintenance and Warranty Manual.
- You are responsible for assuring that at all times the engine hour meter on your Steyr engines is in good working order and in a condition that accurately reflects the total hours that the engines have been operated.
- You are responsible for keeping copies of the completed Warranty Registration Form and of the Commissioning Report.

## Limitations and Exclusions

STEYR MOTORS is not responsible for any engine failure or other problem attributable in whole or in part to any of the following:

- Any application or installation inconsistent with STEYR MOTORS' published application and installation guidelines.
- Abuse or neglect, including but not limited to operation without adequate coolants or lubricants, over-fueling, over-speeding, lack of maintenance of cooling, lubricating or intake systems, improper storage, preservation, rust or corrosion, improper starting, warm-up, run-in or shutdown practices, or failures caused by incorrect oil or by water, dirt or other contaminants in the fuel or oil.
- Unauthorized modifications of the engine.
- Use of a service facility not approved by STEYR MOTORS, or use of parts not supplied or approved by Steyr Motors. For information on approved service partner in your area, please contact STEYR MOTORS or refer to the list of approved service facilities posted on STEYR MOTORS' website at [www.steyr-motors.com](http://www.steyr-motors.com).
- Prolonged or incorrect storage. Prolonged storage, for purposes of this Warranty, is storage for a period of over one (1) year from the date of shipment from the STEYR MOTORS factory.
- Normal wear or wearout of parts.
- Faulty workmanship, whether or not performed by an approved dealer or distributor of STEYR MOTORS, and whether or not occurring in conjunction with a warranty repair.

STEYR MOTORS will not pay for any of the following costs, which shall be the sole responsibility of the Owner:

- The cost of transporting any STEYR MOTORS engine or product to or from the place of warranty service.
- The cost of haulage, launch, docking, or cranes.
- The cost of lubricating oil, antifreeze, filter elements, and other maintenance items replaced during warranty repairs unless such items are not reusable because of the Warrantable Failure.
- The cost of any part supplied, or labor performed, by a service facility not approved by STEYR MOTORS.
- The cost of any part supplied, or labor performed, by a service facility without the prior authorization of STEYR MOTORS.

STEYR MOTORS does not warrant any product or component not specifically identified in the "Products Warranted" section of this document. Please note in particular the following:

- STEYR MOTORS does not warrant any product or component not manufactured by STEYR MOTORS, except for those accessories specifically identified in the "Products Warranted" section of this document that are supplied by STEYR MOTORS and installed by STEYR MOTORS or by a STEYR MOTORS approved distributor or dealer. Examples of items not warranted are stern drives, sail drives, gear boxes, and water jets, control lever, etc.
- STEYR MOTORS does not warrant maintenance components supplied by STEYR MOTORS after 90 days of the date on which warranty coverage commences. Maintenance components include, but are not limited to, sea water pump impellers, zinc plugs, oil filters, fuel filters, air filters, water filters, fuel/water separator filters, belts, automatic belt tensioner, timing belt and idler, gaskets, hoses, fuses, brushes and accommodator, fuel injection nozzle valves, expansion tank pressure caps, and thermostats.





- STEYR MOTORS will not warrant their product with the limited engine warranty if the provided product warranty registration card will not be submitted and received by STEYR MOTORS within 3 years from the date of product manufacturing.

**IN NO EVENT SHALL STEYR MOTORS BE RESPONSIBLE FOR INCIDENTAL OR CONSEQUENTIAL DAMAGES.** Such excluded damages include, but are not limited to, loss of use (including “down time”), loss of income or business revenue, costs of travel, costs of transport, extra costs required to make the Product accessible as a result of particular vessel designs and/or installations (including the removal and/or replacement of partitions or material), personal injury, loss of property, cargo damage, fines, taxes, damages to parts or goods other than products specifically covered by this Warranty, and any other indirect or consequential loss resulting from a Warrantable Failure. **Some states do not allow limitations on how long an implied warranty lasts, so the above limitation may not apply to you.**

**THE WARRANTIES SET FORTH HEREIN ARE THE ONLY WARRANTIES MADE BY STEYR MOTORS WITH RESPECT TO THE PRODUCT. NO DEALER OR DISTRIBUTOR OF STEYR MOTORS IS AUTHORIZED TO MAKE ANY ADDITIONAL WARRANTY, PROMISE, OR REPRESENTATION ON BEHALF OF STEYR MOTORS OR TO MODIFY OR EXTEND THE TERMS OR DURATION OF THIS WARRANTY. ANY WARRANTY IMPLIED BY LAW, INCLUDING ANY IMPLIED WARRANTY OF MERCHANTABILITY OR OF FITNESS FOR A PARTICULAR PURPOSE, SHALL BE LIMITED IN DURATION TO THE TERM OF THIS WARRANTY.**

### **Procedure for Making a Warranty Claim**

Warranty service may be obtained from any approved STEYR MOTORS distributor or dealer. For a list of approved service locations, please refer to Steyr Motors’ website at [www.steyr-motors.com](http://www.steyr-motors.com) or contact STEYR MOTORS’ After sales Division, the contact information for which is provided on the final page of this document.

In the event of a Warrantable Failure arising during the applicable warranty period, a warranty claim must be submitted promptly **IN WRITING**. A warranty claim must be made immediately upon discovery of facts that would lead a reasonably prudent owner to believe that the Product is defective in materials or factory workmanship, but in no event more than 30 days after such discovery.

To make a warranty claim, contact any approved STEYR MOTORS distributor or dealer and present your STEYR MOTORS identification card and your copy of the Warranty Registration Form and Owner Service Log. You may also be required to present your copy of the Commissioning Report all maintenance and service records.

A STEYR MOTORS Warranty Claim Form (a sample copy of which is available from STEYR MOTORS’ website at [www.steyr-motors.com](http://www.steyr-motors.com)) must be completed by the dealer or distributor and returned to STEYR MOTORS in Austria. It is your responsibility to insure that the Warranty Form is properly completed and to retain a copy for your records as proof of the making of a timely warranty claim.

All warranty claims **MUST** be approved by STEYR MOTORS before any warranty work is undertaken. No distributor or dealer of STEYR MOTORS is authorized to approve, or to guarantee approval of, a warranty claim. Any work performed prior to obtaining authorization from STEYR MOTORS will be at the risk of the owner and/or service facility undertaking the work. Upon approval of a warranty claim, you are responsible for making the Product available for repair at the place designated by STEYR MOTORS within a reasonable period of time.

**IMPORTANT: The foregoing procedures for making a warranty claim are mandatory. Failure to comply with the requirements for submitting a warranty claim shall be presumed to have deprived STEYR MOTORS of adequate and timely notice of a defect and shall relieve STEYR MOTORS of any duty of performance under this Warranty.**



## Venue and Applicable Law

This Limited Warranty and the rights and obligations of STEYR MOTORS and of the Owner as they relate to any product supplied by Steyr Motors shall be governed by and construed in accordance with Austrian law, and any legal action instituted against STEYR MOTORS as a result of this Warranty shall be brought in Vienna, Austria. In the event of a legal action commenced against Steyr Motors in the United States, Steyr Motors shall have the option to consent to jurisdiction and to require that the action be submitted to binding arbitration according to the commercial rules of the American Arbitration Association.

## Miscellaneous

This Warranty document consists of the complete and final expression of the intent of the parties with respect to the warranty obligations of STEYR MOTORS. The terms of this Warranty may not be modified except by a writing signed by an authorized representative of STEYR MOTORS. Dealers and distributors of Steyr Motors engines (whether or not approved by Steyr Motors) are not agents of STEYR MOTORS and have no authority to alter the terms of this Warranty or to waive any condition or requirement stated herein.

Should any portion of this Warranty be determined unenforceable in a court of law, the validity and legal effect of the remainder of the document shall not be affected. STEYR MOTORS may in certain circumstances, and at its sole discretion, provide for service outside the scope of this Warranty to update, modify, or repair a product. In that event, Steyr Motors shall not be deemed to have assumed any additional obligation to the owner or to have modified or waived any of the provisions of this Warranty.

The owner shall be responsible for the cost of investigating complaints found not to be attributable to a defect in STEYR MOTORS material or factory workmanship.

Any STEYR MOTORS product or part replaced under warranty will automatically become the property of STEYR MOTORS.

**This warranty gives you specific legal rights, and you may also have other rights which vary from state to state.**

## If You Do Not Receive Satisfactory Warranty Service

STEYR MOTORS strives, through an extensive network of independent distributors and dealers, to provide prompt, courteous, and competent warranty service to owners of Steyr engines. If you fail to receive satisfactory warranty service from a STEYR MOTORS distributor or dealer, please contact STEYR MOTORS after sales division directly. Its contact information is as follows:

STEYR MOTORS, GmbH  
Im Stadtgut B1, 4407  
Steyr, Austria

Phone: +43 7252 222-52  
Fax: +43 7252 222-29  
e-mail: [service@steyr-motors.com](mailto:service@steyr-motors.com)

Erstellt/Issued: 04.02.2011 Kundendienst/After Sales Service	Geprüft und freigegeben/Approved: 04.02.2011/Ing. Rudolf Mandorfer
---	---



## Engine, Gearbox, Boat Model and Hull Identification Numbers

Record your engine and gearbox model and serial numbers immediately after purchase.  
This will enable you to have them available for quick reference when ordering parts or literature.

Engine Model No.: \_\_\_\_\_

Engine Serial No.: \_\_\_\_\_

Gearbox or Stern Drive Model No.: \_\_\_\_\_

Gearbox or Stern Drive Serial No.: \_\_\_\_\_

Ignition Key No.: \_\_\_\_\_

Boat Model No.: \_\_\_\_\_

Hull Identification No. (HIN): \_\_\_\_\_

Recommended Propeller Size: \_\_\_\_\_

### Replacement Parts

Never use parts of unknown quality on your **STEYR MOTORS Marine Engine**.  
Insist on **GENUINE-STEYR MOTORS** Marine parts.

See your local STEYR MOTORS Marine dealer.



### STEYR OWNER IDENTIFICATION CARD

Owner's Name		
Address		
City	State	Zip
Date of commissioning		
MODEL #	SERIAL #	



### DEALER RECORD CARD

ENGINE REGISTRATION	MODEL	SERIAL
OUT DRIVE REGISTRATION	MODEL	SERIAL
TRANSOM MOUNT REGISTRATION	MODEL	SERIAL

Owner's Name		
Address		
City	State	Zip
Date of commissioning	Ignition Key No.	
Boat Mfgr.	Hull No.	
Boat Model	Boat length	

Owner's signature

**IMPORTANT:** The Federal Boat Safety Act requires registration list to be maintained on product sales by manufacturer and DEALER. This is a standard card on which a dealer can keep his records.

Name		
Address		
City	State	Zip
Date of commissioning	Type of Use	
	<input type="checkbox"/> Pleasure	<input type="checkbox"/> Comml <input type="checkbox"/> Govt
Extended Storage Preservation Procedure (refer to Installation Manual Z001007/0, commissioning REPORT)	<input type="checkbox"/> 1 <sup>st</sup> preservation	<input type="checkbox"/> 2 <sup>nd</sup> preservation

Dealer Name		
Address		
City	State	Zip
Owner's e-Mail	Dealer Code	

Engine Registration	Model #	Serial #
---------------------	---------	----------

Boat Mfg	Model
Hull No.	Length
Trailer Vin No.	
Rate Overall Quality of	
Boat	<input type="checkbox"/> Good <input type="checkbox"/> Acceptable <input type="checkbox"/> Poor
Motor	<input type="checkbox"/> <input type="checkbox"/> <input type="checkbox"/>



# SERVICE NETWORK

## AUSTRIA

**STEYR MOTORS GmbH**  
Im Stadtgut B1, 4407 STEYR, AUSTRIA

Phone +43 7252 222-52  
Fax +43 7252 222-29  
e-mail: [service@steyr-motors.com](mailto:service@steyr-motors.com)  
<http://www.steyr-motors.com>

A full list of our worldwide Service network can you found on our homepage under:

**<http://www.steyr-motors.com/network>**

